



ACE24LA1024A

Two-wire Serial EEPROM

Description

The ACE24LA1024A provides 1048576 bits of serial electrically erasable and programmable read-only memory (EEPROM), organized as 131072 words of 8 bits each.

The device is optimized for use in many industrial and commercial applications where low-power and low-voltage operation are essential.

The ACE24LA1024A offers an additional page, named the Identification Page (256 bytes). The Identification Page can be used to store sensitive application parameters which can be (later) permanently locked in Read-only mode.

Features

- Compatible with all I2C bidirectional data transfer protocol
- Memory array:
 - 1024 Kbits (128 Kbytes) of EEPROM
 - Page size: 256 bytes
 - Additional Write lockable page
- Single supply voltage and high speed: 400kHz@2.0V
- Random and sequential Read modes
- Write:
 - Byte Write within 5 ms
 - Page Write within 5 ms
 - Partial Page Writes Allowed
- Write Protect Pin for Hardware Data Protection
- Schmitt Trigger, Filtered Inputs for Noise
- Suppression
- High-reliability
 - Endurance: 4 Million Write Cycles
 - Data Retention: 100 Years
- Enhanced ESD/Latch-up protection
 - HBM 8000V
- 8-lead PDIP/SOP/TSSOP/USON3*2/CSP packages

Absolute Maximum Ratings

DC Supply Voltage	-0.3V to 6.5V
Input / Output Voltage	GND-0.3V to $V_{CC}+0.3V$
Operating Temperature	-40°C to 85°C
Storage Temperature	-65°C to 150°C
Electrostatic pulse (Human Body model)	8000V

Notice: Stresses above those listed under "Absolute Maximum Ratings" may cause permanent damage to this device. These are stress ratings only. Functional operation of this device at these or any other conditions above those indicated in the operational sections of this specification is not implied or intended. Exposure to the absolute maximum rating conditions for extended periods may affect device reliability.



ACE24LA1024A

Two-wire Serial EEPROM

Packaging Type

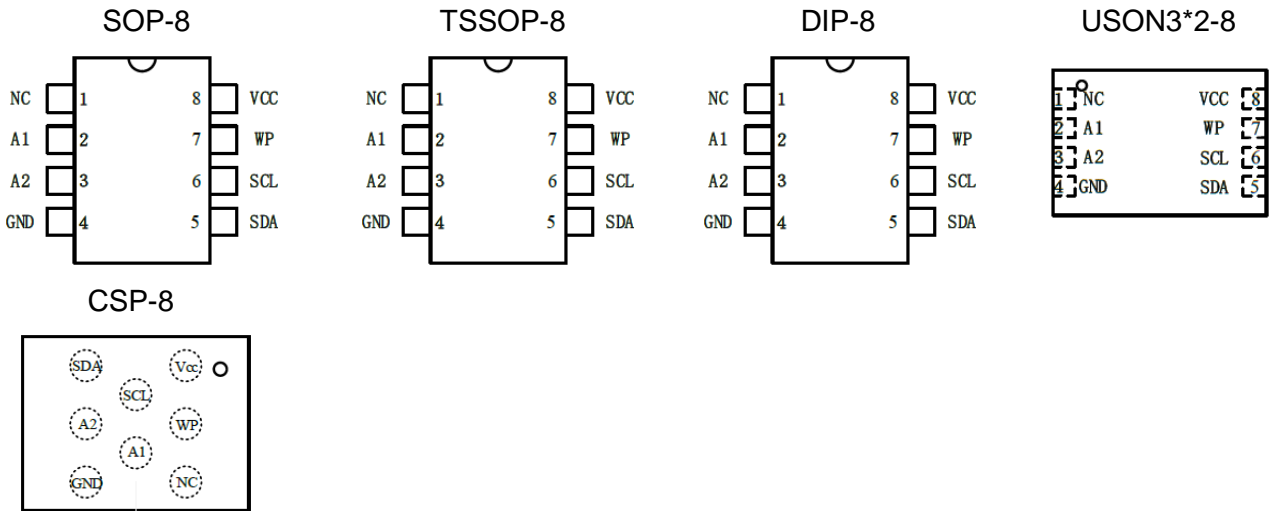

Pin Configurations

Pin Name	Type	Functions
A1-A2	I	Address Inputs
SDA	I/O	Serial Data
SCL	I	Serial Clock Input
WP	I	Write Protect
GND	P	Ground
V _{CC}	P	Power Supply

Ordering information

ACE24LA1024A XX + X H

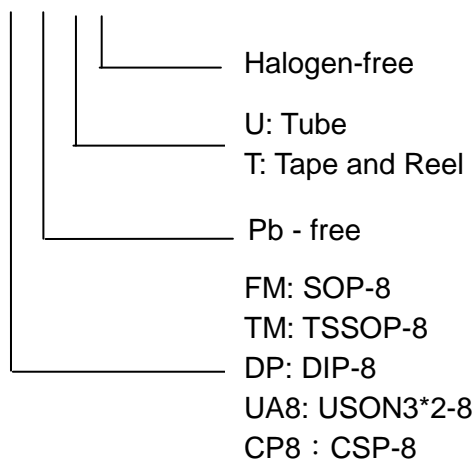



ACE24LA1024A

Two-wire Serial EEPROM

Block Diagram

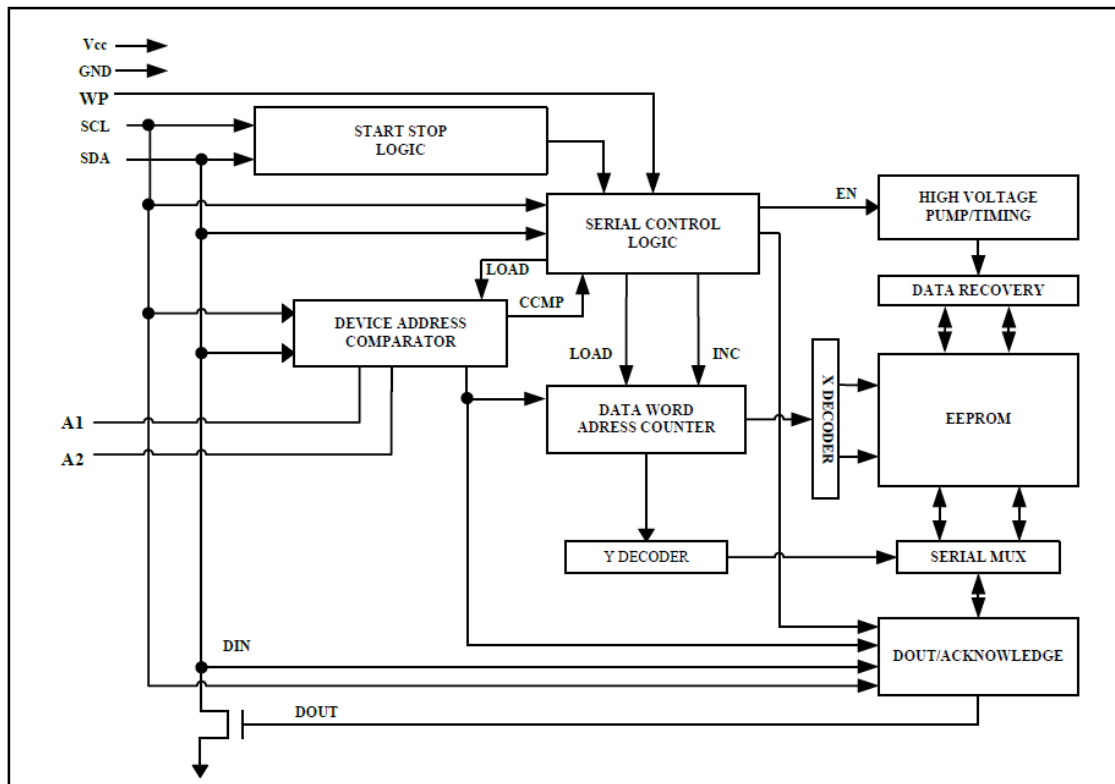

Pin Descriptions

Device/Page Addresses (A2, A1 and A0):

The A2, A1 and A0 pins are device address inputs that are hard wire for the ACE24LA1024A. Eight 256K devices may be addressed on a single bus system (device addressing is discussed in detail under the Device Addressing section).

Serial Data (SDA):

The SDA pin is bi-directional for serial data transfer. This pin is open-drain driven and may be wire-ORed with any number of other open-drain or open-collector devices.

Serial Clock (SCL):

The SCL input is used to positive edge clock data into each EEPROM device and negative edge clock data out of each device.

Write Protect (WP):

The ACE24LA1024A has a Write Protect pin that provides hardware data protection.

The Write Protect pin allows normal read/write operations when connected to ground (GND). When the Write Protection pin is connected to Vcc, the write protection feature is enabled and operates as shown in the following Table 1.

Table1. Write Protect

WP Pin Status	ACE24LA1024A
At V _{CC}	Full (1024K) Array
At GND	Normal Read / Write Operations



ACE24LA1024A

Two-wire Serial EEPROM

Functional Description

Memory Organization

ACE24LA1024A, 1M Serial EEPROM:

Internally organized with 512 pages of 256 bytes each, the 1M requires a 17-bit data word address for random word addressing.

Device Operation

Clock and Data Transitions:

The SDA pin is normally pulled high with an external device. Data on the SDA pin may change only during SCL low time periods (see Figure 1). Data changes during SCL high periods will indicate a start or stop condition as defined below.

Start Condition:

A high-to-low transition of SDA with SCL high is a start condition which must precede any other command (see Figure 2).

Stop Condition:

A low-to-high transition of SDA with SCL high is a stop condition. After a read sequence, the stop command will place the EEPROM in a standby power mode (see Figure 2).

Acknowledge:

All addresses and data words are serially transmitted to and from the EEPROM in 8-bit words. The EEPROM sends a "0" to acknowledge that it has received each word. This happens during the ninth clock cycle.

Standby Mode:

The ACE24LA1024A features a low-power standby mode which is enabled: (a) upon power-up and (b) after the receipt of the STOP bit and the completion of any internal operations.

Memory Reset:

After an interruption in protocol, power loss or system reset, any two-wire part can be reset by following these steps:

1. Clock up to 9 cycles.
2. Look for SDA high in each cycle while SCL is high and then.
3. Create a start condition.



ACE24LA1024A

Two-wire Serial EEPROM

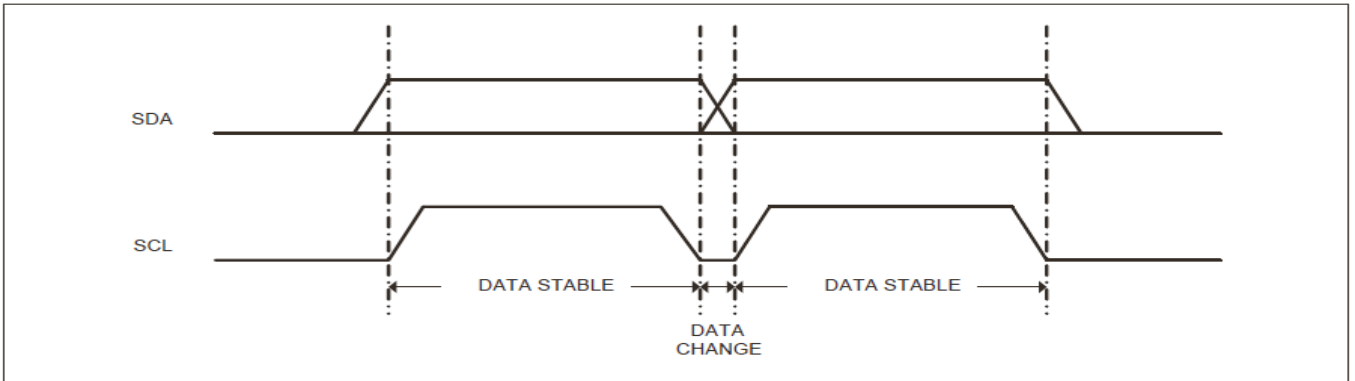

Figure 1: Data Validity

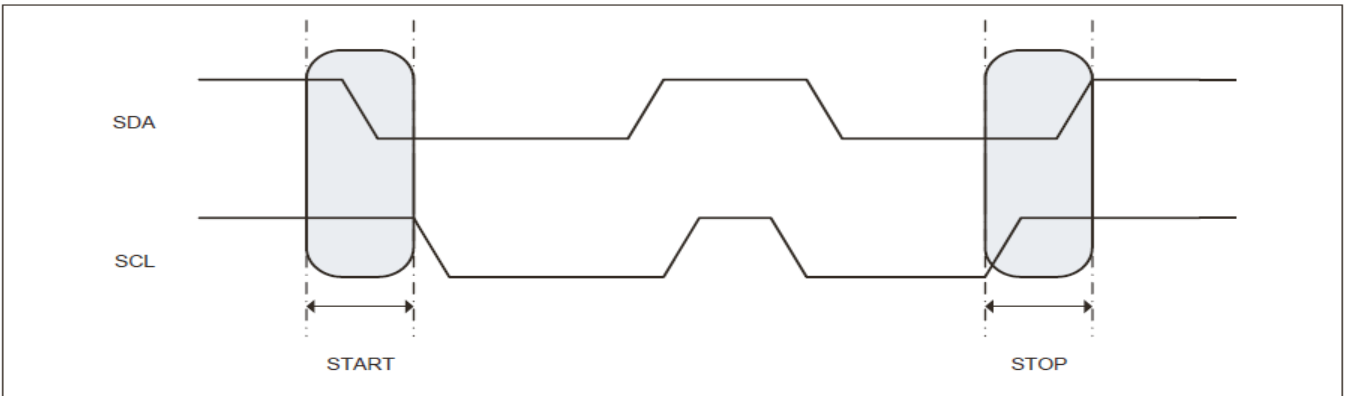

Figure 2: Start and Stop Definition

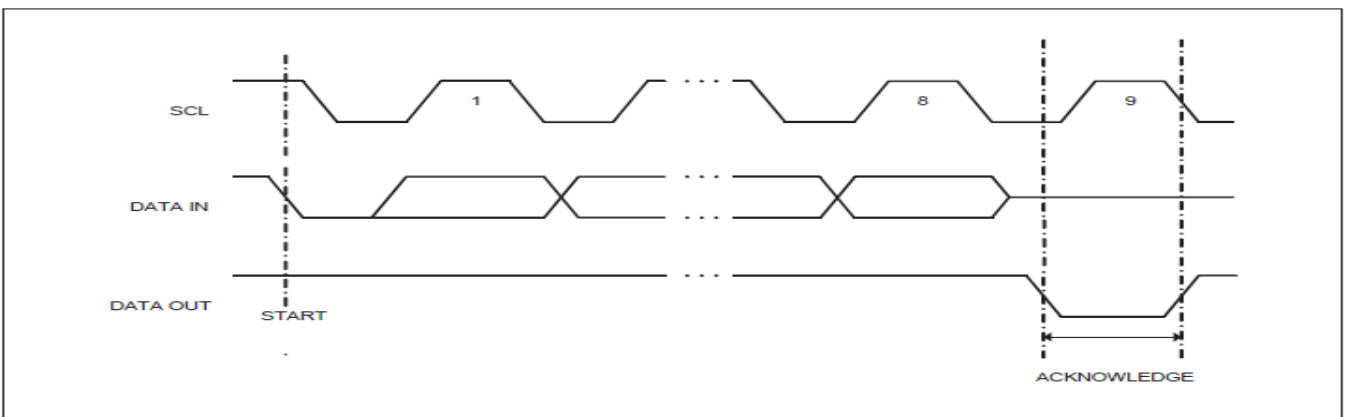

Figure 3: Output Acknowledge



ACE24LA1024A

Two-wire Serial EEPROM

Device Addressing

The 1M EEPROM devices all require an 8-bit device address word following a start condition to enable the chip for a read or write operation (see Figure 4)

The device address word consists of a mandatory "1", "0" sequence for the first four most significant bits as shown. This is common to all the Serial EEPROM devices.

The 1M EEPROM uses A2 and A1 device address bits to allow as much as eight devices on the same bus. These 3 bits must be compared to their corresponding hardwired input pins. The A2 and A1 pins use an internal proprietary circuit that biases them to a logic low condition if the pins are allowed to float.

The eighth bit of the device address is the read/write operation select bit. A read operation is initiated if this bit is high and a write operation is initiated if this bit is low.

Upon a compare of the device address, the EEPROM will output a "0". If a compare is not made, the chip will return to a standby state.

MSB				LSB			
1	0	1	0	A2	A1	B16	R/W
B15	B14	B13	B12	B11	B10	B9	B8
B7	B6	B5	B4	B3	B2	B1	B0

Figure 4: Device Address and two 8-bit data word address

DATA SECURITY: The ACE24LA1024A has a hardware data protection scheme that allows the user to write protect the entire memory when the WP pin is at VCC.



Write Operations

Byte Write:

A write operation requires two 8-bit data word address following the device address word and acknowledgment. Upon receipt of this address, the EEPROM will again respond with a "0" and then clock in the first 8-bit data word. Following receipt of the 8-bit data word, the EEPROM will output a "0" and the addressing device, such as a microcontroller, must terminate the write sequence with a stop condition. At this time the EEPROM enters an internally timed write cycle, t_{WR} , to the nonvolatile memory. All inputs are disabled during this write cycle and the EEPROM will not respond until the write is complete (see Figure 5).

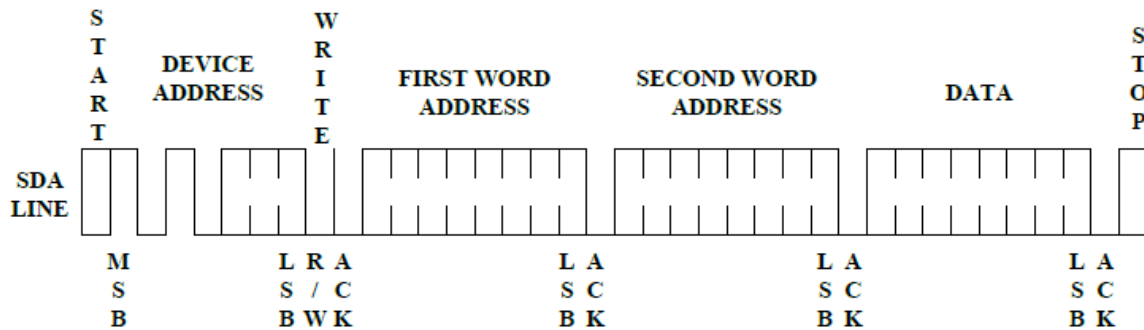

Figure 5. Byte Write

Page Write:

A write operation requires two 8-bit data word address following the device address word and acknowledgment. Upon receipt of this address, the EEPROM will again respond with a "0" and then clock in the first 8-bit data word. Following receipt of the 8-bit data word, the EEPROM will output a "0" and the addressing device, such as a microcontroller, must terminate the write sequence with a stop condition. At this time the EEPROM enters an internally timed write cycle, t_{WR} , to the nonvolatile memory. All inputs are disabled during this write cycle and the EEPROM will not respond until the write is complete (see Figure 6).

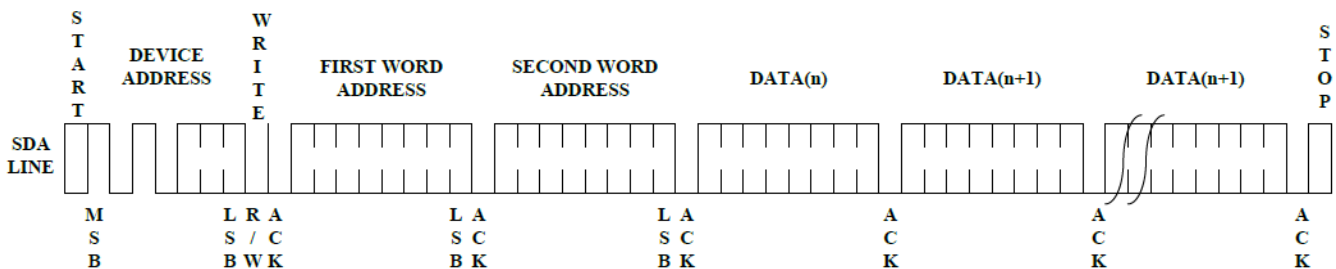

Figure 6. Page Write



ACE24LA1024A

Two-wire Serial EEPROM

The data word address lower eight bits are internally incremented following the receipt of each data word. The higher data word address bits are not incremented, retaining the memory page row location. When the word address, internally generated, reaches the page boundary, the following byte is placed at the beginning of the same page. If more than 256 data words are transmitted to the EEPROM, the data word address will "roll over" and previous data will be overwritten.

Write Identification Page:

The Identification Page (256 bytes) is an additional page which can be written and (later) permanently locked in Read-only mode. It is written by issuing the Write Identification Page instruction. This instruction uses the same protocol and format as Page Write (into memory array), except for the following differences:

- Device type identifier = 1011b
- MSB address bits B16/B8 are don't care except for address bit B10 which must be "0".

LSB address bits B7/B0 define the byte address inside the Identification page.

If the Identification page is locked, the data bytes transferred during the Write Identification Page instruction are not acknowledged (NoAck).

Acknowledge Polling:

Once the internally timed write cycle has started and the EEPROM inputs are disabled, acknowledge polling can be initiated. This involves sending a start condition followed by the device address word. The read/write bit is representative of the operation desired. Only if the internal write cycle has completed will the EEPROM respond with a "0", allowing the read or write sequence to continue.

Read Operations

Read operations are initiated the same way as write operations with the exception that the read/write select bit in the device address word is set to "1". There are three read operations: current address read, random address read and sequential read.

Current Address Read:

The internal data word address counter maintains the last address accessed during the last read or write operation, incremented by one. This address stays valid between operations as long as the chip power is maintained. The address "roll over" during read is from the last byte of the last memory page to the first byte of the first page. The address "roll over" during write is from the last byte of the current page to the first byte of the same page. Once the device address with the read/write select bit set to "1" is clocked in and acknowledged by the EEPROM, the current address data word is serially clocked out. The microcontroller does not respond with an input "0" but does generate a following stop condition (see Figure 7).



ACE24LA1024A

Two-wire Serial EEPROM

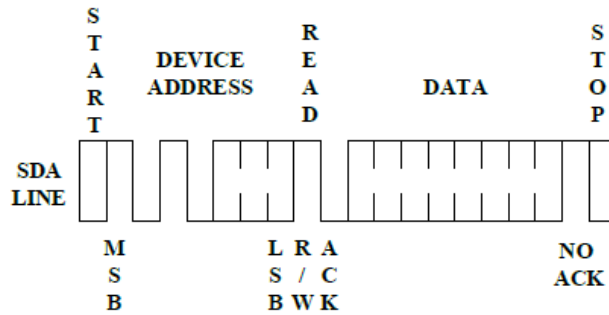

Figure 7. Current Address Read

Random Read:

A random read requires a "dummy" byte write sequence to load in the data word address. Once the device address word and data word address are clocked in and acknowledged by the EEPROM, the microcontroller must generate another start condition. The microcontroller now initiates a current address read by sending a device address with the read/write select bit high. The EEPROM acknowledges the device address and serially clocks out the data word. The microcontroller does not respond with a "0" but does generate a following stop condition (see Figure 8)

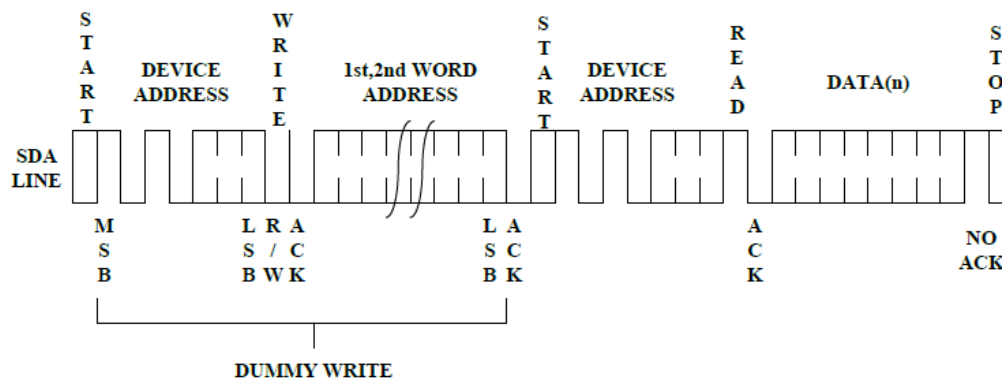

Figure 8. Random Read

Sequential Read:

Sequential reads are initiated by either a current address read or a random address read. After the microcontroller receives a data word, it responds with an acknowledge. As long as the EEPROM receives an acknowledge, it will continue to increment the data word address and serially clock out sequential data words. When the memory address limit is reached, the data word address will "roll over" and the sequential read will continue. The sequential read operation is terminated when the microcontroller does not respond with a "0" but does generate a following stop condition (see Figure9).

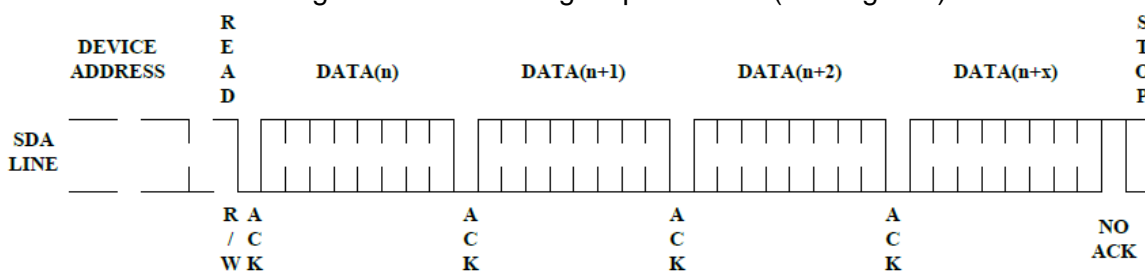

Figure 9. Sequential Read



ACE24LA1024A

Two-wire Serial EEPROM

Read identification page: The Identification Page (256 bytes) is an additional page which can be written and (later) permanently locked in Read-only mode.

The Identification Page can be read by issuing an Read Identification Page instruction. This instruction uses the same protocol and format as the Random Address Read (from memory array) with device type identifier defined as 1011b. The MSB address bits B16/B8 are don't care, the LSB address bits B7/B0 define the byte address inside the Identification Page. The number of bytes to read in the ID page must not exceed the page boundary (e.g.: when reading the Identification Page from location 10d, the number of bytes should be less than or equal to 246, as the ID page boundary is 256 bytes)

Lock Identification Page: The Lock Identification Page instruction (Lock ID) permanently locks the Identification page in Read-only mode. The Lock ID instruction is similar to Byte Write (into memory array) with the following specific conditions:

Device type identifier = 1011b

Address bit B10 must be '1'; all other address bits are don't care

The data byte must be equal to the binary value xxxx xx1x, where x is don't care

DC Characteristics

Applicable over recommended operating range from: $T_A = -40^{\circ}\text{C}$ to 85°C , $V_{CC} = 2\text{V}$ to 5.5V , (unless otherwise noted).

Parameter	Symbol	Min	Typ	Max	Units	Condition
Supply Voltage	V_{CC1}	2.0		5.5	V	
Supply Current $V_{CC}=5.0\text{V}$	I_{CC1}		0.26	0.5	mA	READ at 400KHZ
Supply Current $V_{CC}=5.0\text{V}$	I_{CC2}		0.28	0.5	mA	WRITE at 400KHZ
Supply Current $V_{CC}=5.0\text{V}$	I_{SB1}		0.03	0.5	μA	$V_{IN}=V_{CC}$ or V_{SS}
Input Leakage Current	I_{L1}		0.10	1.0	μA	$V_{IN}=V_{CC}$ or V_{SS}
Output Leakage Current	I_{LO}		0.05	1.0	μA	$V_{OUT}=V_{CC}$ or V_{SS}
Input Low Level	V_{IL1}	-0.3		$V_{CC}\times 0.3$	V	$V_{CC}=1.7\text{V}$ to 5.5V
Input High Level	V_{IH1}	$V_{CC}\times 0.7$		$V_{CC}+0.3$	V	$V_{CC}=1.7\text{V}$ to 5.5V
Output Low Level $V_{CC}=1.7\text{V}$	V_{OL1}			0.2	V	$I_{OL}=2.1\text{mA}$
Output Low Level $V_{CC}=5.0\text{V}$	V_{OL2}			0.4	V	$I_{OL}=3.0\text{mA}$

Pin Capacitance

Applicable over recommended operating range from: $T_A = 25^{\circ}\text{C}$, $f = 400\text{kHz}$, $V_{CC} = 2.7\text{V}$.

Parameter	Symbol	Max	Units	Condition
Input/Output Capacitance(SDA)	CI/O	8	pF	$V_{I/O} = 0\text{V}$
Input Capacitance(A1,A2,SCL)	CIN	6	pF	$V_{IN} = 0\text{V}$



ACE24LA1024A

Two-wire Serial EEPROM

AC Characteristics

Applicable over recommended operating range from $T_A = -40^{\circ}\text{C}$ to 85°C , $V_{CC} = 2.0\text{V}$ to 5.5V , $CL = 1$ TTL Gate and 100 pF (unless otherwise noted)

Parameter	Symbol	$2.0\text{V} \leq V_{CC} < 2.5\text{V}$			$2.5\text{V} \leq V_{CC} < 5.5\text{V}$			Units
		Min	Typ	Max	Min	Typ	Max	
Clock Frequency, SCL	f_{SCL}			400			1000	KHZ
Clock Pulse Width Low	T_{LOW}	1.3			0.5			μs
Clock Pulse Width High	T_{HIGH}	0.6			0.26			μs
Noise Suppression Time	T_{I}			50			50	ns
Clock Low to Data Out Valid	T_{AA}			0.9			0.45	μs
Time the bus must be free before a new transmission can Start	T_{BUF}	1.3			0.5			μs
Start Hold Time	$T_{\text{HD,STA}}$	0.6			0.25			μs
Start Setup Time	$T_{\text{SU,STA}}$	0.6			0.25			μs
Data In Hold Time	$T_{\text{HD,DAT}}$	0			0			μs
Data In Setup Time	$T_{\text{SU,DAT}}$	100			100			ns
Inputs Rise Time (1)	T_{R}			0.3			0.12	μs
Inputs Fall Time (1)	T_{F}			0.3			0.12	μs
Stop Setup Time	$T_{\text{SU,STO}}$	0.6			0.25			μs
Data Out Hold Time	T_{DH}	50			50			ns
Write Cycle Time	T_{WR}		3.5	5		3.5	5	ms
5.0V, 25°C , Page Mode(1)	Endurance	4M			4M			Write Cycle

Notes:

- This parameter is characterized and is not 100% tested.
- AC measurement conditions: R_L (connects to VCC): 1.3 k
 Input pulse voltages: 0.3 VCC to 0.7 VCC
 Input rise and fall time: 50 ns
 Input and output timing reference voltages: 0.5 VCC
 The value of R_L should be concerned according to the actual loading on the user's system.



ACE24LA1024A

Two-wire Serial EEPROM

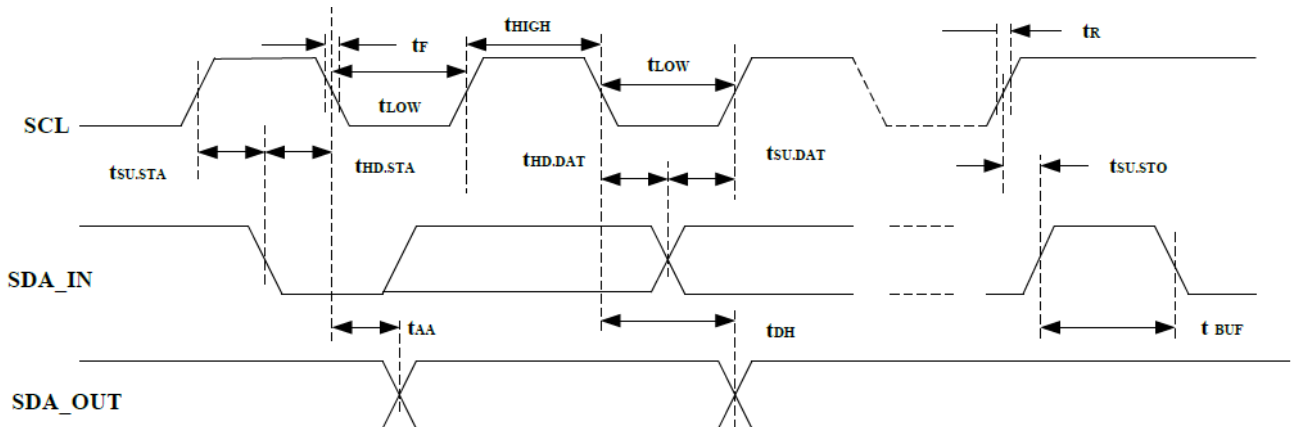

Figure 10. SCL: Serial Clock, SDA: Serial Data I/O

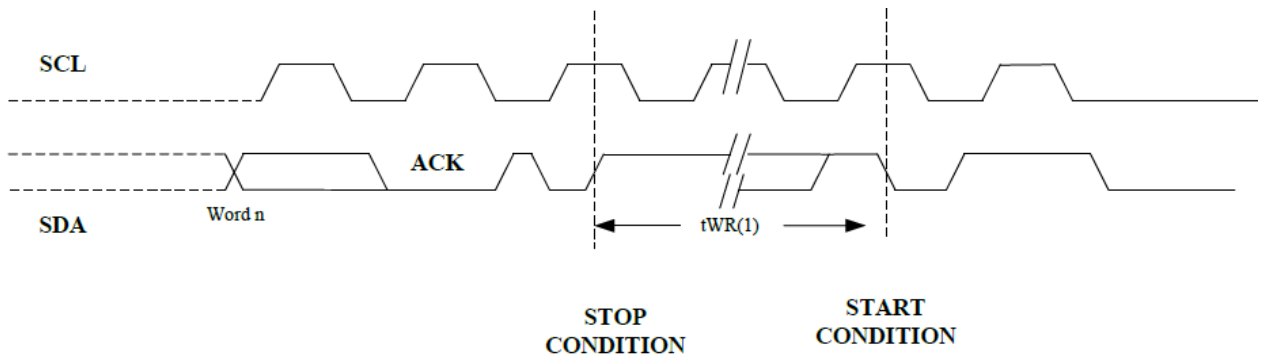

Figure 11. SCL: Serial Clock, SDA: Serial Data I/O

Note: The write cycle time t_{WR} is the time from a valid stop condition of a write sequence to the end of the internal clear/write cycle.



ACE24LA1024A

Two-wire Serial EEPROM

Packaging information

DIP-8

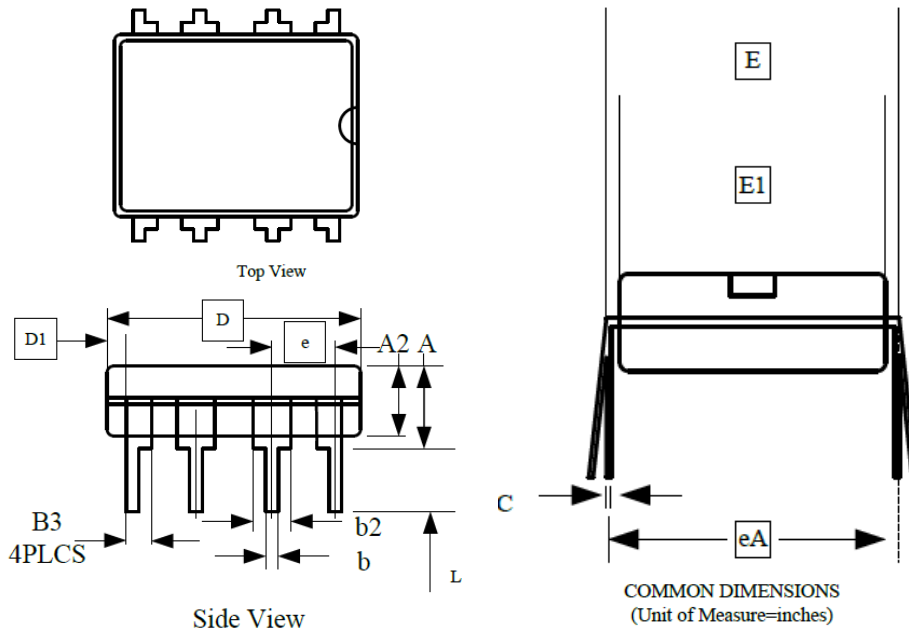

SYMBOL	MIN	NOM	MAX	NOTE
A			0.210	2
A2	0.115	0.130	0.195	
b	0.014	0.018	0.022	5
b2	0.045	0.060	0.070	6
b3	0.030	0.039	0.045	6
c	0.008	0.010	0.014	
D	0.355	0.365	0.400	3
D1	0.005			3
E	0.300	0.310	0.325	4
E1	0.240	0.250	0.280	3
e	0.100BSC			
eA	0.300BSC			4
L	0.115	0.130	0.150	2

Notes:

1. This drawing is for general information only; refer to JEDEC Drawing MS-001, Variation BA for additional information.
2. Dimensions A and L are measured with the package seated in JEDEC seating plane Gauge GS-3.
3. D, D1 and E1 dimensions do not include mold Flash or protrusions. Mold Flash or protrusions shall not exceed 0.010 inch.
4. E and eA measured with the leads constrained to be perpendicular to datum.
5. Pointed or rounded lead tips are preferred to ease insertion.
6. b2 and b3 maximum dimensions do not include Dambar protrusions. Dambar protrusions shall not exceed 0.010 (0.25 mm).



ACE24LA1024A

Two-wire Serial EEPROM

Packaging information

SOP-8

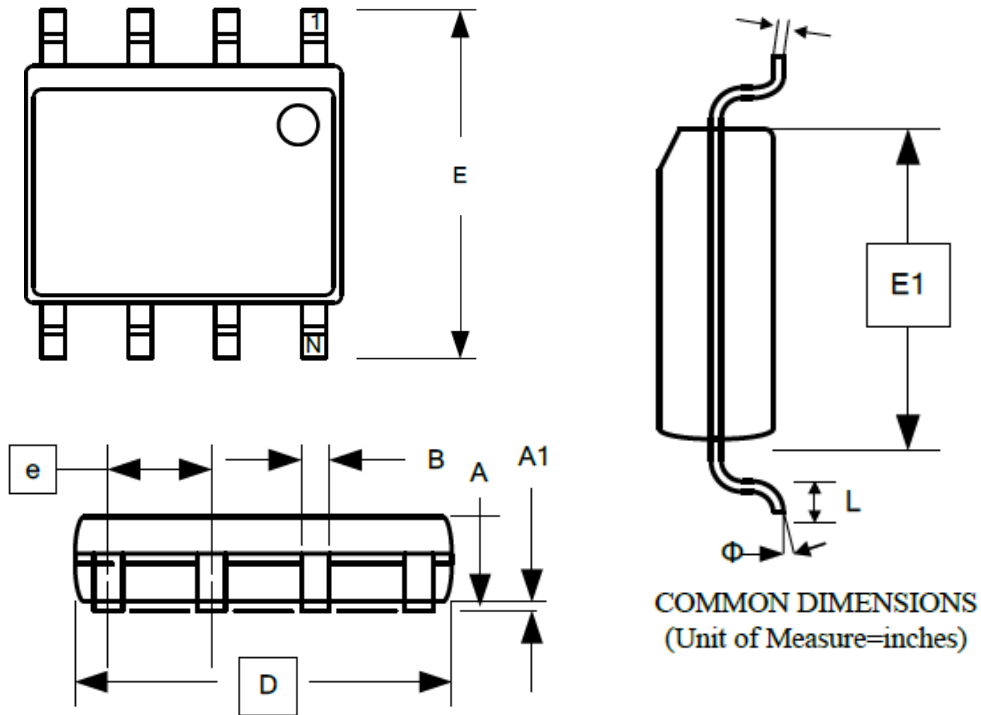

COMMON DIMENSIONS
(Unit of Measure=Inches)

SYMBOL	MIN	NOM	MAX
A	1.35		1.75
A1	0.10		0.25
b	0.31		0.51
C	0.17		0.25
D	4.80		5.00
E1	3.81		3.99
E	5.79		6.20
e	1.27BSC		
L	0.40		1.27
Φ	0"		8"

Notes:

These drawings are for general information only. Refer to JEDEC Drawing MS-012, Variation AA for proper dimensions, tolerances, datums, etc.



ACE24LA1024A

Two-wire Serial EEPROM

Packaging information

TSSOP-8

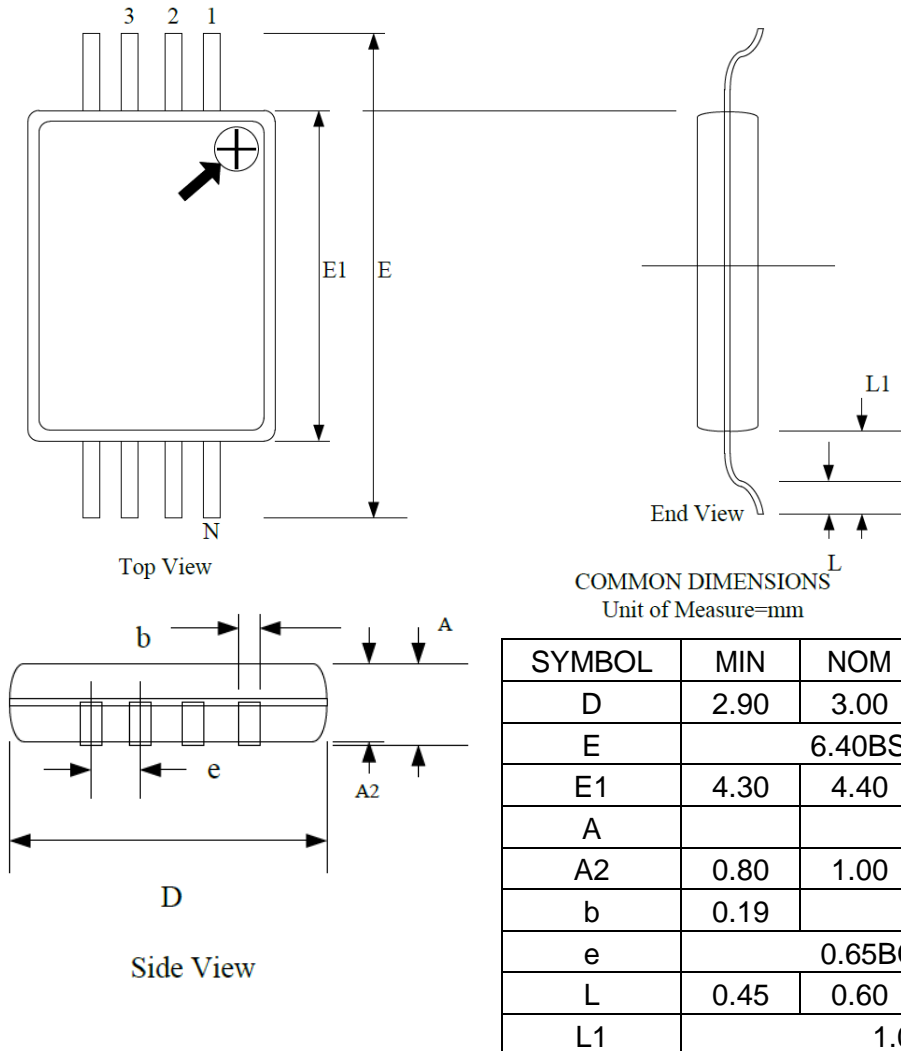

Notes:

1. This drawing is for general information only. Refer to JEDEC Drawing MO-153, Variation AA, for proper dimensions, tolerances, datums, etc.
2. Dimension D does not include mold Flash, protrusions or gate burrs. Mold Flash, protrusions and gate burrs shall not exceed 0.15 mm (0.006 in) per side.
3. Dimension E1 does not include inter-lead Flash or protrusions. Inter-lead Flash and protrusions shall not exceed 0.25 mm (0.010 in) per side.
4. Dimension b does not include Dambar protrusion. Allowable Dambar protrusion shall be 0.08 mm total in excess of the b dimension at maximum material condition. Dambar cannot be located on the lower radius of the foot. Minimum space between protrusion and adjacent lead is 0.07 mm.
5. Dimension D and E1 to be determined at Datum Plane H.



ACE24LA1024A

Two-wire Serial EEPROM

Packaging information

USON3*2-8

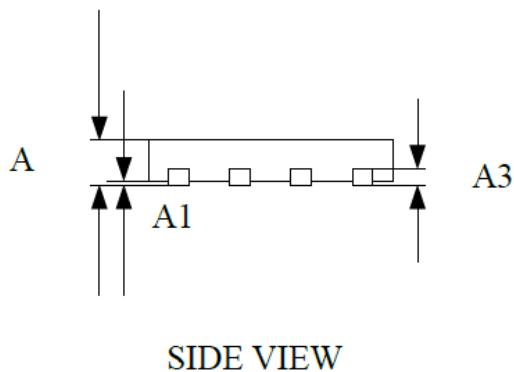
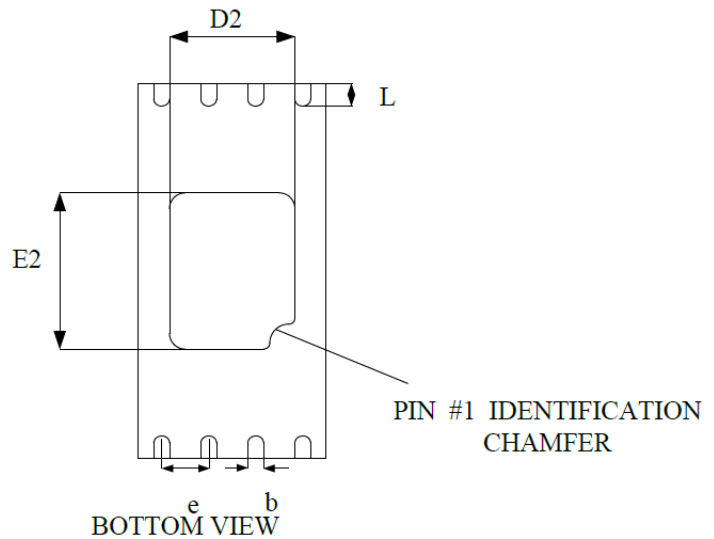
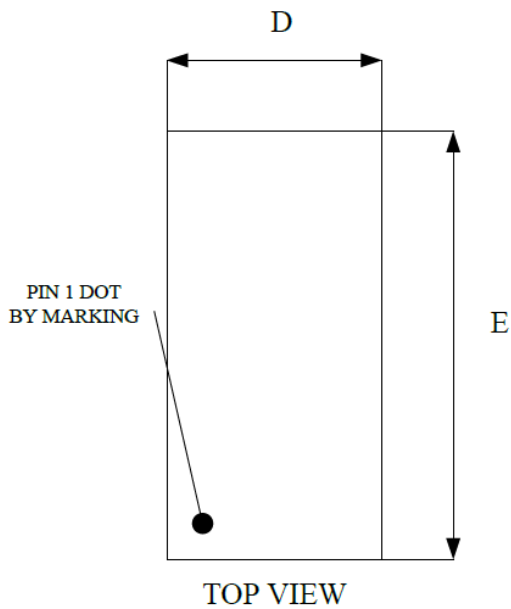

COMMON DIMENSION(MM)			
PKG	UT:ULTRA THIN		
REF	MIN	NOM	MAX
A	>0.50	0.55	0.60
A1	0.00		0.05
A3	0.15REF		
D	1.95	2.00	2.05
E	2.95	3.00	3.05
b	0.20	0.25	0.30
L	0.20	0.30	0.40
D2	1.25	1.40	1.50
E2	1.15	1.30	1.40
e	0.50BSC		



ACE24LA1024A

Two-wire Serial EEPROM

Packaging information

CSP-8

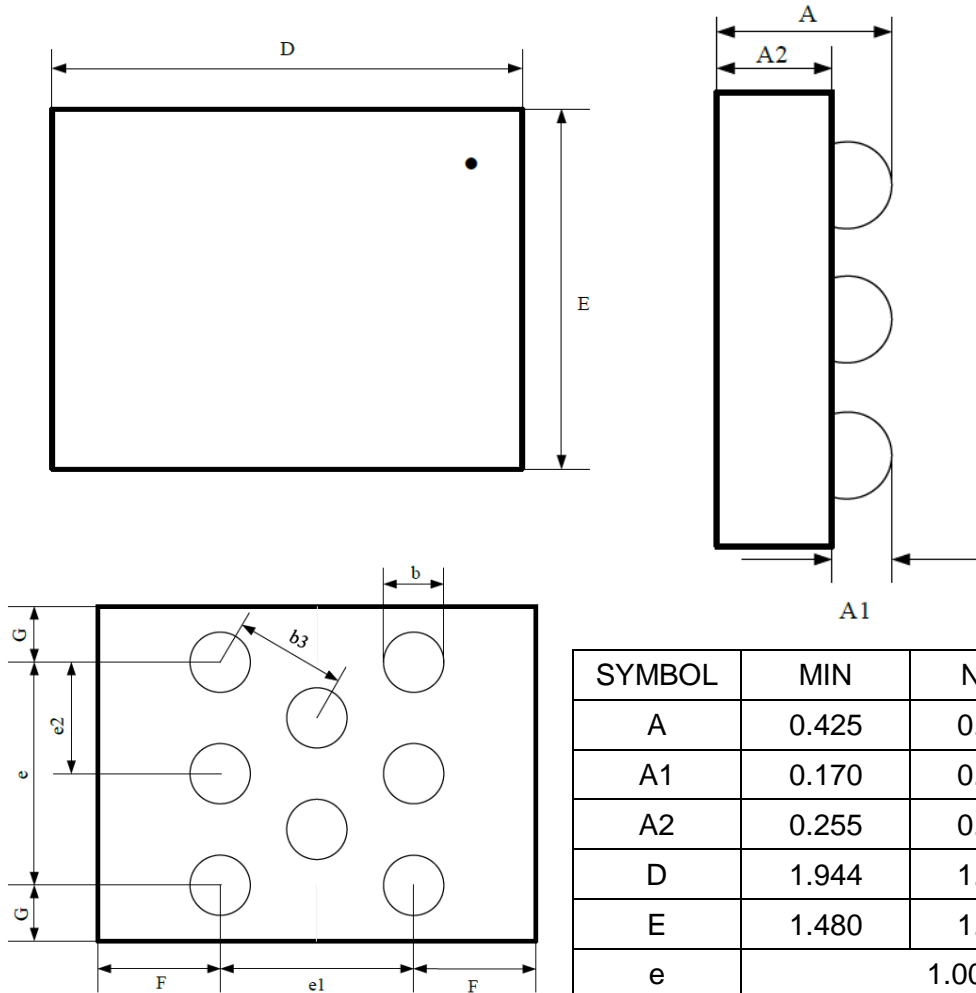

SYMBOL	MIN	NOM	MAX
A	0.425	0.465	0.505
A1	0.170	0.190	0.210
A2	0.255	0.275	0.295
D	1.944	1.964	1.984
E	1.480	1.500	1.520
e	1.000BSC		
e1	0.866BSC		
e2	0.500BSC		
e3	0.500BSC		
b	0.270BSC		
F	0.529	0.549	0.569
G	0.230	0.250	0.270



ACE24LA1024A

Two-wire Serial EEPROM

Notes

ACE does not assume any responsibility for use as critical components in life support devices or systems without the express written approval of the president and general counsel of ACE Electronics Co., LTD. As used herein:

1. Life support devices or systems are devices or systems which, (a) are intended for surgical implant into the body, or (b) support or sustain life, and whose failure to perform when properly used in accordance with instructions for use provided in the labeling, can be reasonably expected to result in a significant injury to the user.
2. A critical component is any component of a life support device or system whose failure to perform can be reasonably expected to cause the failure of the life support device or system, or to affect its safety or effectiveness.

ACE Technology Co., LTD.
<http://www.ace-ele.com/>