



# ACE577C

## 40V 150mA Low Consumption Linear Regulator

### Description

ACE577C series is a group of positive voltage output, low power consumption, low dropout voltage regulator. It can provide 150mA output current when input / output voltage differential drops to 400mV ( $V_{out} = 5V$ ), and it also provides fold back short-circuit protection, thermal protection and output current limit function. The very low power consumption of ACE577C ( $I_q = 2.5\mu A$ ) can greatly improve natural life of batteries.

ACE577C can provide output value in the range of 1.2V~5.0V in 0.1V steps. It also can customize on command.

ACE577C includes high accuracy voltage reference, error amplifier, and current limit circuit and output driver module.

ACE577C has well load transient response and good temperature characteristic, And it uses trimming technique to guarantee output voltage accuracy within  $\pm 2\%$ .

### Features

- Low Power Consumption: 2.5 $\mu A$ (Typ.)
- Maximum Output Current: 150mA
- Small Dropout Voltage
- 400mV@100mA ( $V_{out}=5V$ )
- Input Voltage Range: 3V~40V
- Output Voltage Range: 1.2V~5.0V ( $V_{out}>5V$  customized)
- Highly Accurate:  $\pm 2\%$ ( $\pm 1\%$  customized)
- Output Current Limit: 180mA

### Application

- Battery Powered equipment
- Power Management of MP3 、 PDA 、 DSC 、 Mouse 、 PS2 Games
- Reference Voltage Source Regulation after Switching Power



# ACE577C

## 40V 150mA Low Consumption Linear Regulator

### Absolute Maximum Ratings

Parameter		Value
Max Input Voltage		48V
Operating Junction Temperature(Tj)		125°C
Ambient Temperature(Ta)		-40 °C-85°C
Power Dissipation (P <sub>D</sub> @Ta=25°C)	SOT-89-3	500mW
Package thermal resistance(θ <sub>JC</sub> )		25°C/W
Package thermal resistance(θ <sub>JA</sub> )		90°C/W
Storage Temperature(Ts)		-40°C -150°C
Lead Temperature & Time		260°C,10S

Note: Exceed these limits to damage to the device.

Exposure to absolute maximum rating conditions may affect device reliability.

### Packaging Type

SOT-89-3

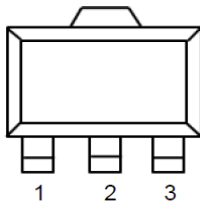

### Pin Configuration

SOT-89-3(A)	SOT-89-3(B)	NAME	Description
1	2	GND	Ground
2	3	Vin	Supply voltage input
3	1	Vout	Output voltage

### Ordering Information

ACE577CXX XX+ H

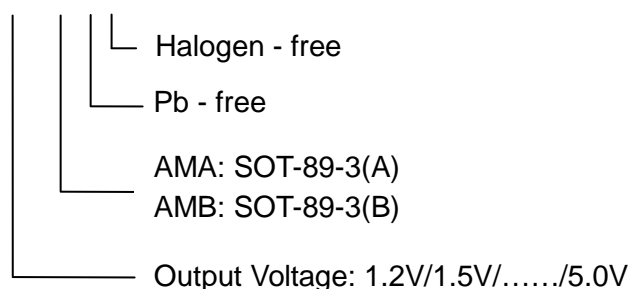



# ACE577C 40V 150mA Low Consumption Linear Regulator

## Typical Application

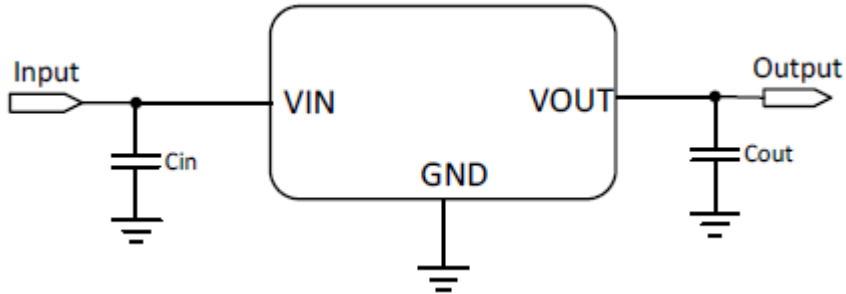

## Recommended Work Conditions

Item	Min	Max.	Unit
Input Voltage Range	3	40	V
Ambient Temperature	-40	85	□°C

## Block Diagram

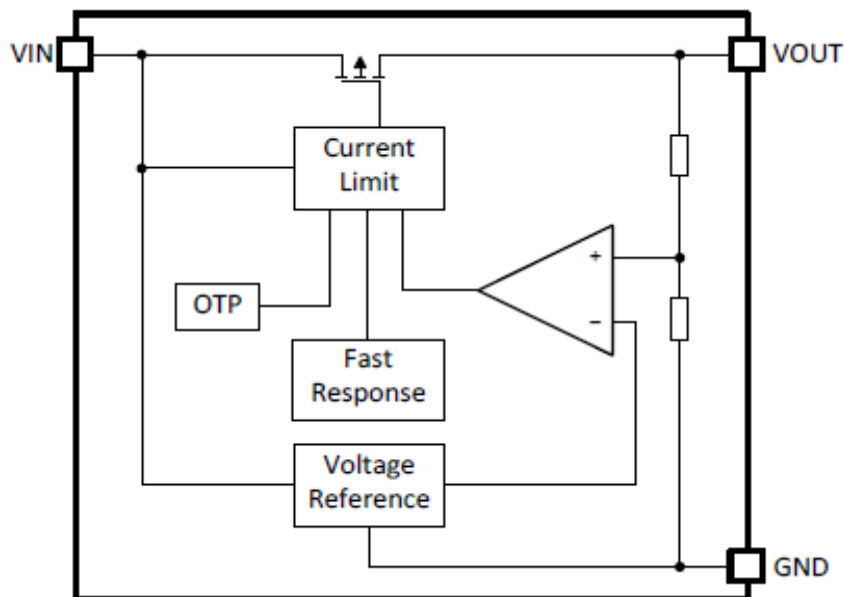



# ACE577C

## 40V 150mA Low Consumption Linear Regulator

### Explanation

ACE577C is a series of low dropout voltage and low power consumption regulator. Its application circuit is very simple, which only needs two outside capacitors. It is composed of these modules: high accuracy voltage reference, current limit circuit, error amplifier, output driver and power transistor.

Current Limit module can keep chip and power system away from danger when load current is more than 180mA.

ACE577C uses trimming technique to assure the accuracy of output value within  $\pm 2\%$ , at the same time, temperature compensation is elaborately considered in this chip, which makes ACE577C's temperature coefficient within  $\pm 100\text{ppm}/^\circ\text{C}$ .

### Electrical Characteristics

(Test Conditions:  $C_{in}=1\mu\text{F}$ ,  $C_{out}=1\mu\text{F}$ ,  $T_a=25^\circ\text{C}$ , Unless Otherwise Specified)

Parameter	Symbol	Conditions	Min	Typ	Max	Units
Input Voltage	$V_{in}$		3		40	V
Output Voltage	$V_{out}$	$V_{in}-V_{out}=1\text{V}$ $1\text{mA}\leq I_{out}\leq 30\text{mA}$	$V_{out}$ $\times 0.98$	$V_{out}$	$V_{out}$ $\times 1.02$	V
			$V_{out}$ $-0.03$		$V_{out}$ $+0.03$	
Maximum Output Current	$I_{out}(\text{Max.})$	$V_{in}-V_{out}=1\text{V}$	150			mA
Input-Output Voltage Differential	Dropout Voltage	$I_{out}=100\text{mA}$ , $V_{out}=5\text{V}$		400		mV
Line Regulation	$\frac{\Delta V_{out}}{\Delta V_{in} \cdot V_{out}}$	$I_{out}=10\text{mA}$ , $4\text{V}\leq V_{in}\leq 40\text{V}$		0.2	0.3	%/V
Load Regulation	$\Delta V_{out}$	$V_{in}=\text{Set } V_{out}+1\text{V}$ $1\text{mA}\leq I_{out}\leq 100\text{mA}$		20	40	mV
Quiescent Current	$I_q$	$V_{in}=\text{Set } V_{out}+1\text{V}$		2.5	5	$\mu\text{A}$
Output Voltage Temperature Coefficient	$\frac{\Delta V_{out}}{\Delta T \cdot V_{out}}$	$I_{out}=10\text{mA}$		$\pm 100$		ppm/ $^\circ\text{C}$
Thermal Shutdown				130		$^\circ\text{C}$



# ACE577C 40V 150mA Low Consumption Linear Regulator

## Typical Performance Characteristics

### Load Regulation

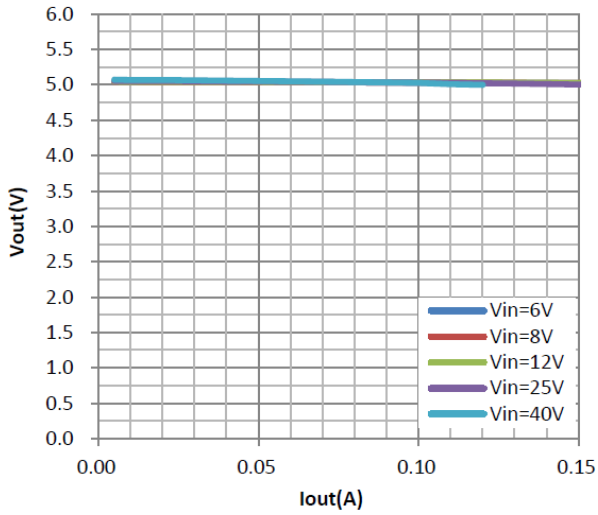

### Line Regulation

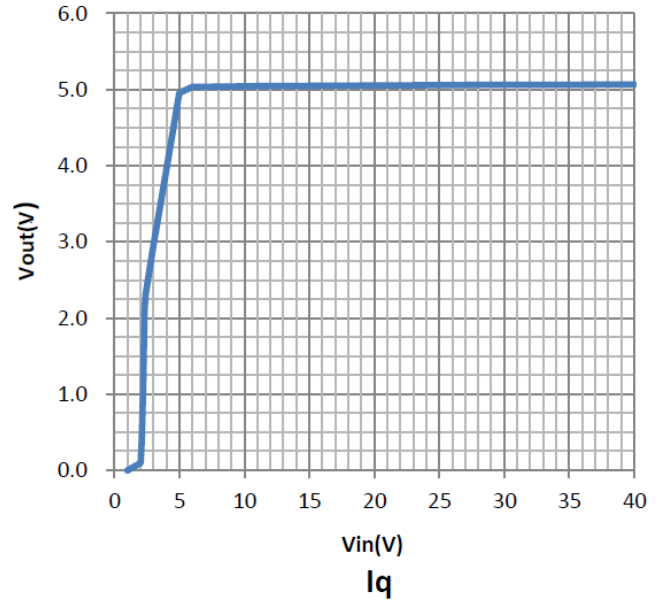

### Dropout

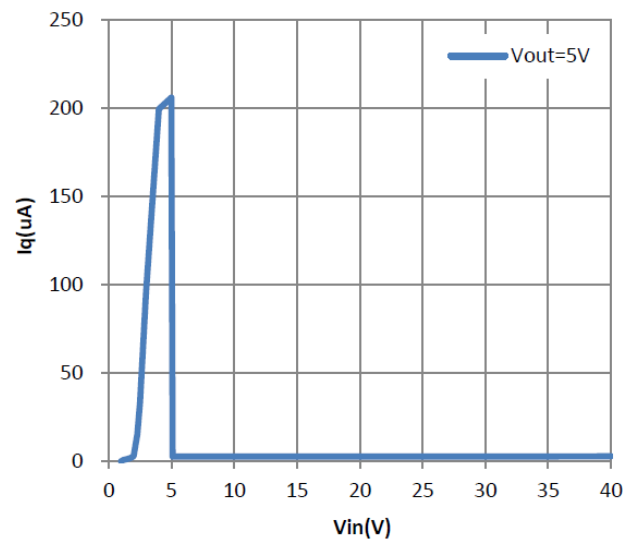
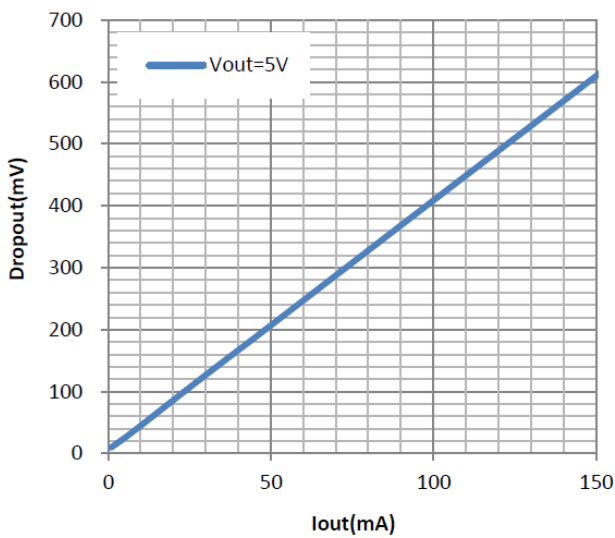

### Current Limit

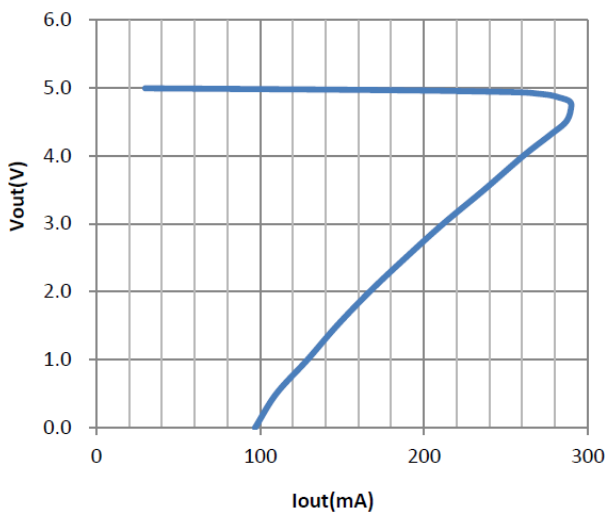



# ACE577C

## 40V 150mA Low Consumption Linear Regulator

**Line transient response**  
 $V_{in}=6V\sim 7V$ ,  $I_{out}=10mA$   
Ch1— $V_{in}$ , Ch2— $V_{out}$

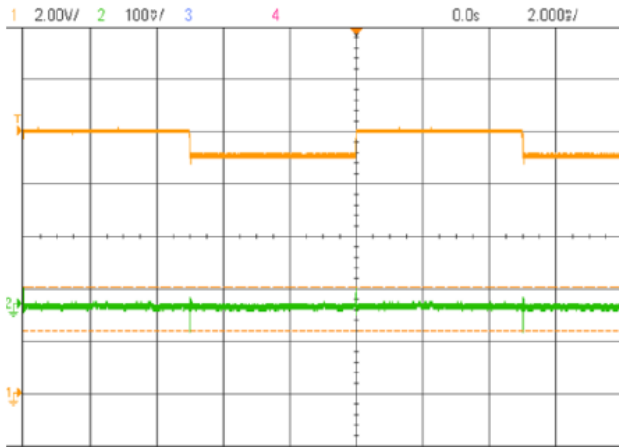

**Load transient response**  
 $V_{in}=12V$ ,  $I_{out}=10mA\sim 100mA$   
Ch2— $V_{out}$ , Ch4— $I_{out}$

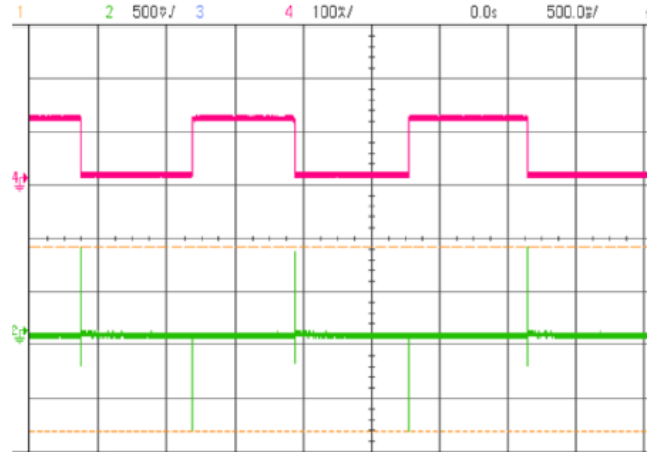



# ACE577C 40V 150mA Low Consumption Linear Regulator

## Packing Information

### SOT-89-3

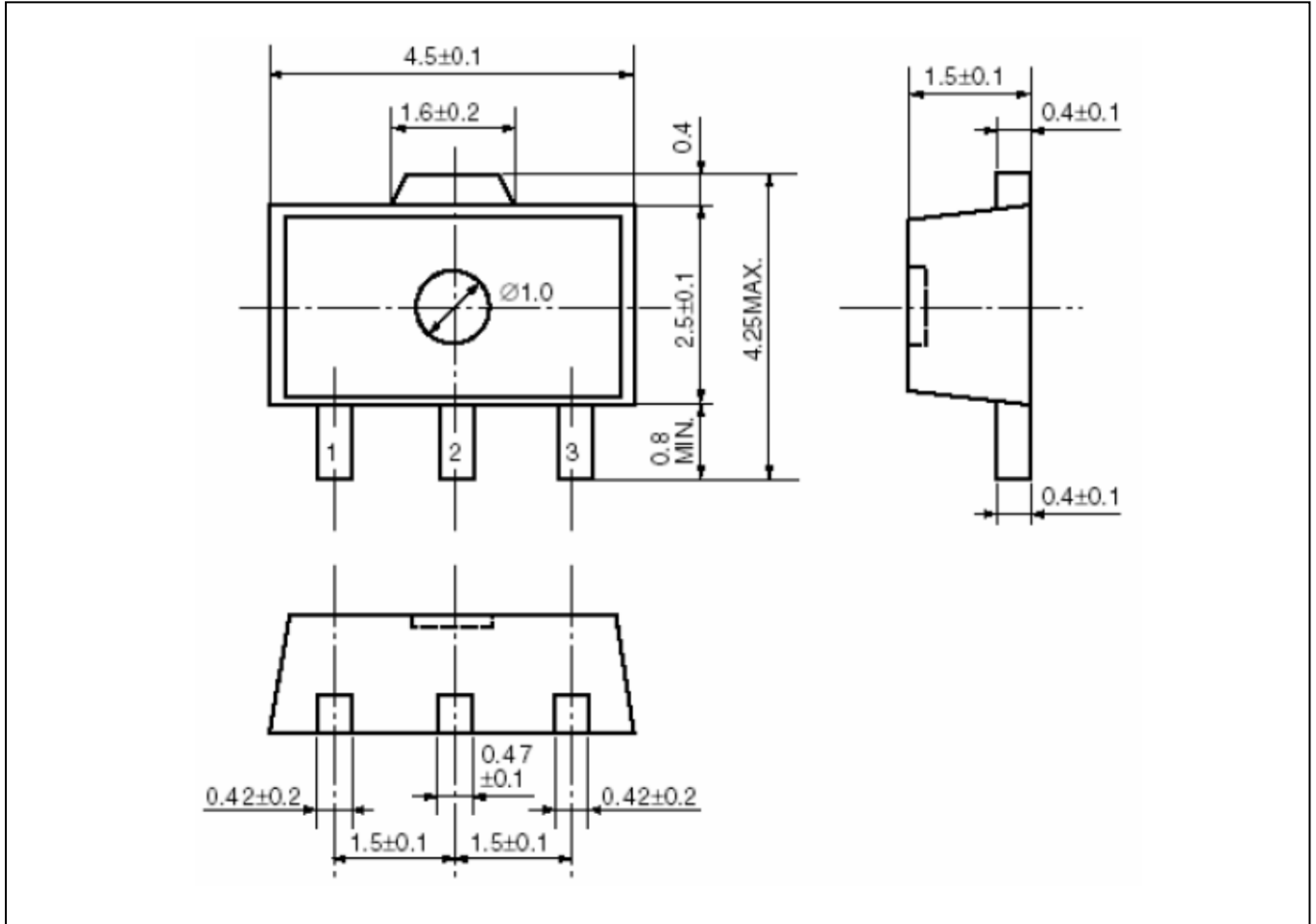



# ACE577C

## 40V 150mA Low Consumption Linear Regulator

### Notes

ACE does not assume any responsibility for use as critical components in life support devices or systems without the express written approval of the president and general counsel of ACE Technology Co., LTD. As stated herein:

1. Life support devices or systems are devices or systems which, (a) are intended for surgical implant into the body, or (b) support or sustain life, and whose failure to perform when properly used in accordance with instructions for use provided in the labeling, can be reasonably expected to result in a significant injury to the user.
2. A critical component is any component of a life support device or system whose failure to perform can be reasonably expected to cause the failure of the life support device or system, or to affect its safety or effectiveness.