



# ACE24C256C

## Two-wire serial EEPROM

### Description

The ACE24C256C is a 256-Kbit I<sup>2</sup>C-compatible Serial EEPROM (Electrically Erasable Programmable Memory) device. It contains a memory array of 32 K × 8 bits, which is organized in 64-byte per page. ACE24C256C provides the following devices for different application.

### Features

- Single Supply Voltage and High Speed
  - Minimum operating voltage down to 1.7V
  - 1 MHz clock from 2.5V to 5.5V
  - 400kHz clock from 1.7V to 2.5V
- Low power CMOS technology
  - Read current 400uA, maximum
  - Write current 1.6mA, maximum
- Schmitt Trigger, Filtered Inputs for Noise Suppression
- Sequential & Random Read Features
- 64 byte Page Write Modes, Partial Page Writes Allowed
- Write protect of the whole memory array
- Additional Write Lockable Page
- Self-timed Write Cycle (5ms maximum)
- High Reliability
  - Endurance: 2 Million Write Cycles
  - Data Retention: 100 Years
  - HBM: 6KV
  - Latch up Capability: +/- 200mA (25°C & 125°C)
- Package: DIP, SOP, TSSOP,MSOP,TDFN,UDFN and SOT23-5

### Absolute Maximum Ratings

Storage Temperature	-60°C to 150°C
Operation Temperature	-40°C to 125°C
Maximum Operation Voltage	6.25V
Voltage on Any Pin with Respect to Ground.	-1.0V to (V <sub>cc</sub> +1.0)V
DC Output Current	5.0 mA

Notice: Stresses above those listed under “Absolute Maximum Ratings” may cause permanent damage to the device. This is a stress rating only and functional operation of the device at those or any other conditions above those indicated in the operational listings of this specification is not implied. Exposure to maximum rating conditions for extended periods may affect device reliability.



# ACE24C256C Two-wire serial EEPROM

## Packaging Type

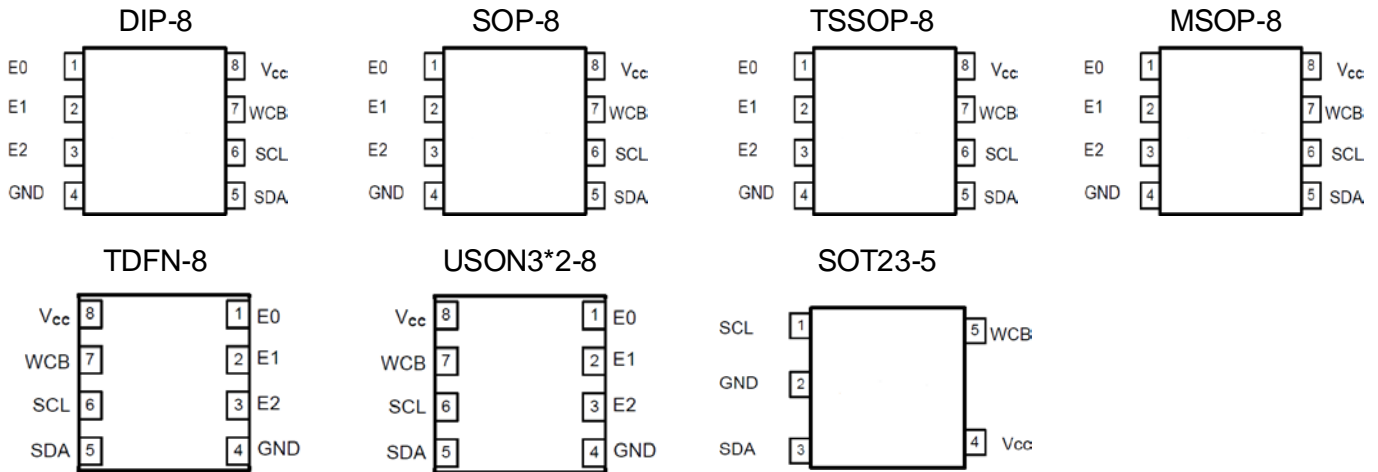

## Pin Configurations

Pin Name	Type	Functions
E0	I/O	Slave Address Setting
E1	Input	Slave Address Setting
E2	Input	Slave Address Setting
GND	Ground	Ground
SDA	I/O	Serial Data Input and Serial Data Output
SCL	Input	Serial Clock Input
WCB	Input	Write Control, Low Enable Write
V <sub>CC</sub>	Power	Power

## Ordering information

ACE24C256C XX + X H

- Halogen - free
- U : Tube
- T : Tape and Reel
- Pb - free
- DP : DIP-8
- FM : SOP-8
- TM : TSSOP-8
- OM : MSOP8
- DM : TDFN-8
- UA8 : USON3\*2-8
- BN : SOT-23-5



# ACE24C256C Two-wire serial EEPROM

## Block Diagram

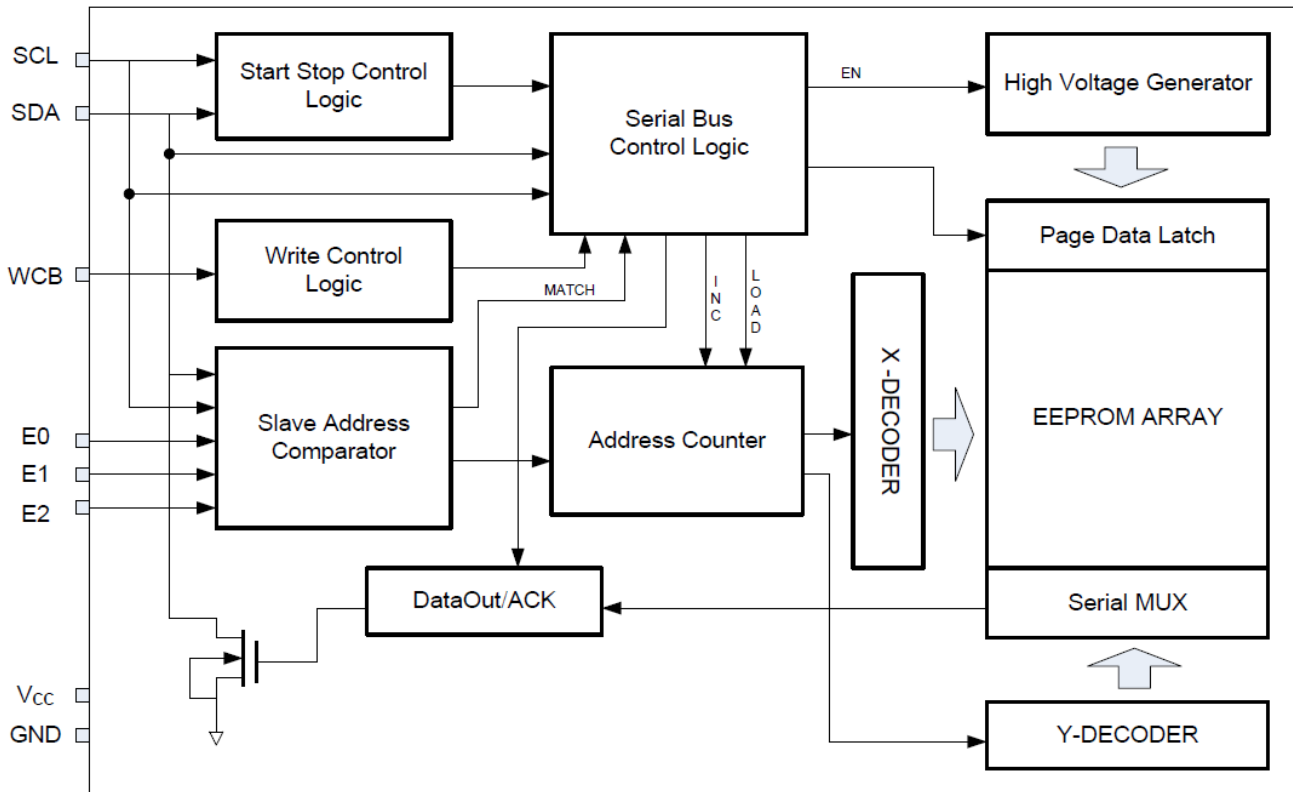

## Pin Descriptions

**Serial Clock (SCL):** The SCL input is used to positive-edge clock data in and negative-edge clock data out of each device.

**Serial Data (SDA):** The SDA pin is bidirectional for serial data transfer. This pin is open drain driven and may be wire-ORed with any number of other open-drain or open-collector devices.

**Device Addresses (E2, E1, E0):** The E2, E1, and E0 pins are device address inputs. Typically, the E2, E1, and E0 pins are for hardware addressing and a total of 8 devices can be connected on a single bus system. If these pins are left floating, the E2, E1, and E0 pins will be internally pulled down to GND.

**Write Control (WCB):** The Write Control input, when WCB is connected directly to  $V_{CC}$ , all write operations to the memory are inhibited. When connected to GND, allows normal write operations. If the pin is left floating, the WCB pin will be internally pulled down to GND.

## Pin Capacitance

Test Conditions:  $T_A = 25^\circ\text{C}$ ,  $F = 1\text{MHz}$ ,  $V_{CC} = 5.0\text{V}$ .

Symbol	Parameter	Max	Units	Test Condition
$C_{I/O}$	Input/Output Capacitance (SDA)	8	pF	$V_{I/O}=\text{GND}$
$C_{IN}$	Input Capacitance (E0,E1,E2,WCB,SCL)	6	pF	$V_{IN}=\text{GND}$



# ACE24C256C

## Two-wire serial EEPROM

### DC Characteristics

Unless otherwise specified,  $V_{CC} = 1.7V$  to  $5.5V$ ,  $T_A = -40^{\circ}C$  to  $125^{\circ}C$

Symbol	Parameter	Test Condition	Min	Typ	Max	Units
$V_{CC}$	Supply Voltage		1.7		5.5	V
$I_{SB}$	Supply Current	$V_{CC}@3.3V, T_A = 85^{\circ}C$			1.0	$\mu A$
		$V_{CC}@5.5V, T_A = 85^{\circ}C$			3.0	$\mu A$
		$V_{CC}@5.5V, T_A = 105^{\circ}C$			6.0	$\mu A$
		$V_{CC}@5.5V, T_A = 125^{\circ}C$			10.0	$\mu A$
$I_{CC1}$	Supply Read Current	$V_{CC}=5.5V, \text{Read at } 400Khz$		0.2	0.4	mA
$I_{CC2}$	Supply Write Current	$V_{CC}=5.5V, \text{Write at } 400Khz$		0.8	1.6	mA
$I_{LI}$	Input Leakage Current	$V_{IN} = V_{CC}$ or GND		0.10	1.0	$\mu A$
$I_{LO}$	Output Leakage Current	$V_{OUT} = V_{CC}$ or GND		0.05	1.0	$\mu A$
$V_{IL}$	Input Low Level		-0.6		$0.3V_{CC}$	V
$V_{IH}$	Input High Level		$-0.7V_{CC}$		$V_{CC}+0.5$	V
$V_{OL2}$	Output Low Level	$I_{OL} = 1.5 \text{ mA}$			0.2	V
	$V_{CC}=1.7V(\text{SDL})$					
$V_{OL1}$	Output Low Level	$I_{OL} = 2.1 \text{ mA}$			0.4	V
	$V_{CC}=3.0V(\text{SDL})$					



# ACE24C256C

## Two-wire serial EEPROM

### AC Characteristics

Unless otherwise specified,  $V_{CC} = 1.7V$  to  $5.5V$ ,  $T_A = -40^{\circ}C$  to  $125^{\circ}C$ ,  $CL = 100pF$ , Test Conditions are listed in Notes2

Symbol	Parameter	$1.7 \leq V_{CC} < 2.5$		$2.5 \leq V_{CC} \leq 5.5$		Units
		Min	Max	Min	Max	
$f_{SCL}$	Clock Frequency, SCL		400		1000	kHz
$t_{LOW}$	Clock Pulse Width Low	1.3		0.4		$\mu s$
$t_{HIGH}$	Clock Pulse Width High	0.6		0.4		$\mu s$
$t_{AA}$	Clock Low to Data Out Valid	0.05	0.9	0.05	0.55	$\mu s$
$t_I$	Noise Suppression Time		0.1		0.05	$\mu s$
$t_{BUF}$	Time the bus must be free before a new transmission can Start	1.3		0.5		$\mu s$
$t_{HD,STA}$	Start Hold Time	0.6		0.25		$\mu s$
$t_{SU,STA}$	Start Setup Time	0.6		0.25		$\mu s$
$t_{HD,DAT}$	Data In Hold Time	0		0		$\mu s$
$t_{SU,DAT}$	Data In Setup Time	0.1		0.1		$\mu s$
$t_R$	Inputs Rise Time <sup>(1)</sup>		0.3		0.3	$\mu s$
$t_F$	Inputs Fall Time <sup>(1)</sup>		0.3		0.1	$\mu s$
$t_{SU,STO}$	Stop Setup Time	0.6		0.25		$\mu s$
$t_{DH}$	Data Out Hold Time	0.05		0.05		$\mu s$
$t_{SU,WCB}$	WCB pin Setup Time	1.2		0.6		$\mu s$
$t_{HD,WCB}$	WCB pin Hold Time	1.2		0.6		$\mu s$
$t_{WR}$	Write Cycle Time		5		5	ms

Notes: 1. This parameter is ensured by characterization not 100% tested

2.AC measurement conditions:

$R_L$  (connects to  $V_{CC}$ ): 1.3k (2.5V, 5.5V), 10k (1.7V)

Input pulse voltages:  $0.3 V_{CC}$  to  $0.7 V_{CC}$

Input rise and fall times:  $\leq 50ns$

Input and output timing reference voltages:  $0.5V_{CC}$

### Reliability Characteristic<sup>(1)</sup>

Symbol	Parameter	Min.	Max.	Unit
EDR <sup>(2)</sup>	Endurance	2,000,000		Write cycles
DRET	Data retention	100		Years

Notes: 1. This parameter is ensured by characterization and is not 100% tested

2. Under the condition:  $25^{\circ}C$ , 3.3V, Page mode



# ACE24C256C Two-wire serial EEPROM

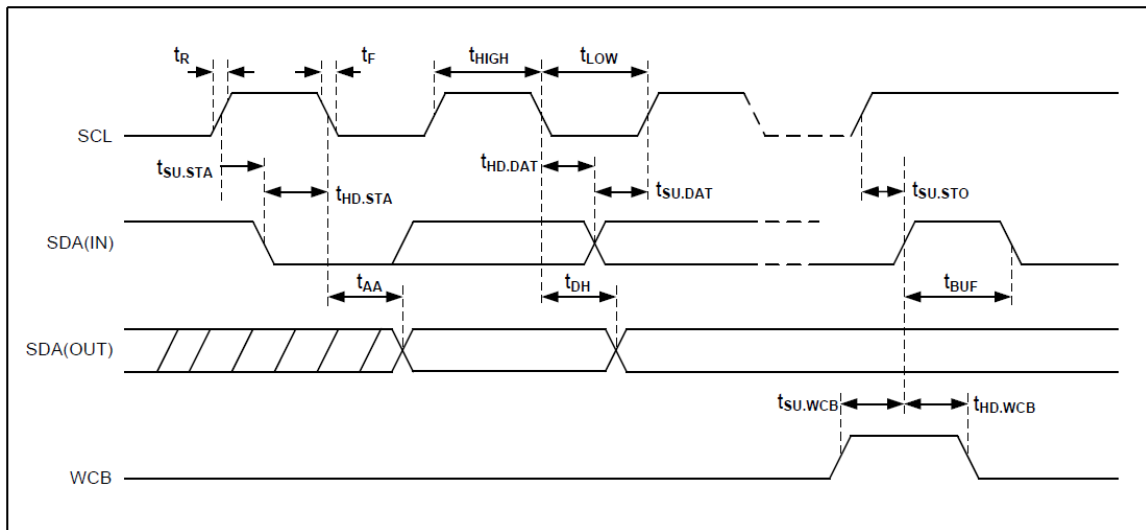

Figure1 : Bus Timing

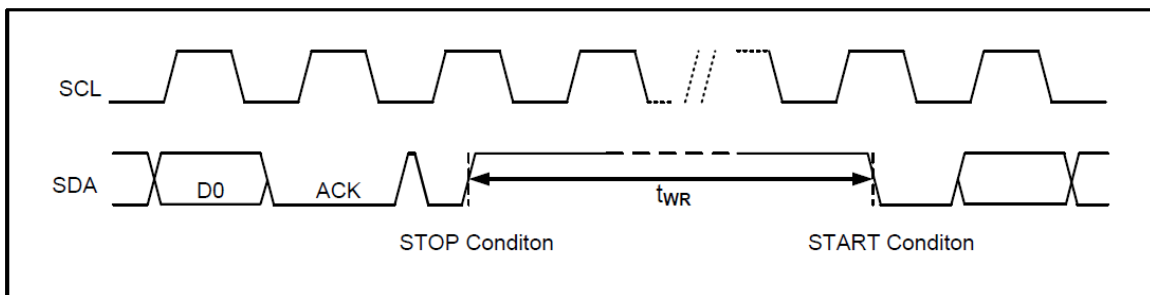

Figure2 : Write Cycle Timing

## Device Operation

### Data Input

The SDA pin is normally pulled high with an external device. Data on the SDA pin may change only during SCL low time periods (see to Figure 3). Data changes during SCL high periods will indicate a start or stop condition as defined below.

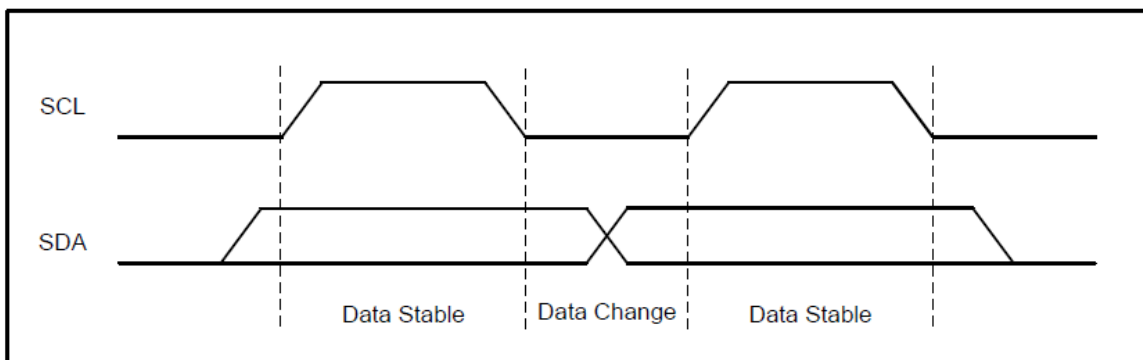

Figure3 : Data Validity



# ACE24C256C Two-wire serial EEPROM

## Start Condition

A high-to-low transition of SDA with SCL high is a start condition which must precede any other command (see to Figure 4).

## Stop Condition

A low-to-high transition of SDA with SCL high is a stop condition. After a read sequence, the stop command will place the ACE24C256C in a standby power mode (see Figure 4).

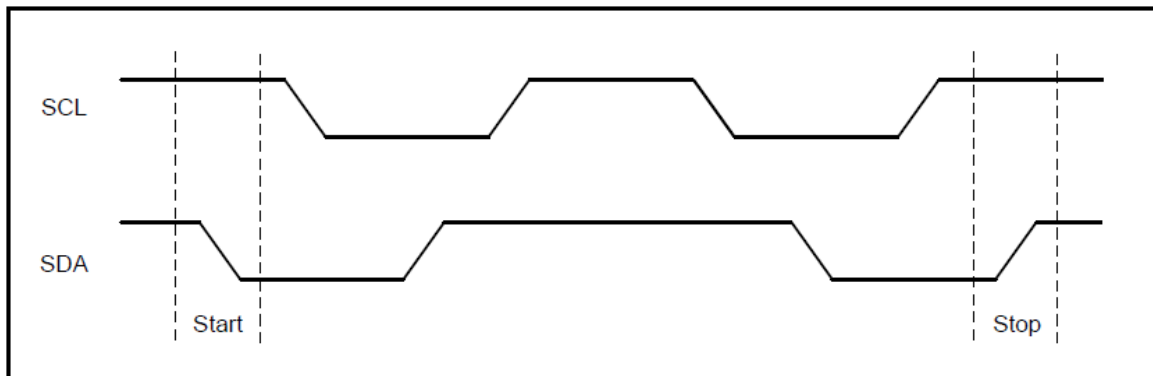

Figure4 : Start and Stop Definition

## Acknowledge (ACK)

All addresses and data words are serially transmitted to and from the ACE24C256C in 8-bit words. The ACE24C256C sends a “0” to acknowledge that it has received each word. This happens during the ninth clock cycle.

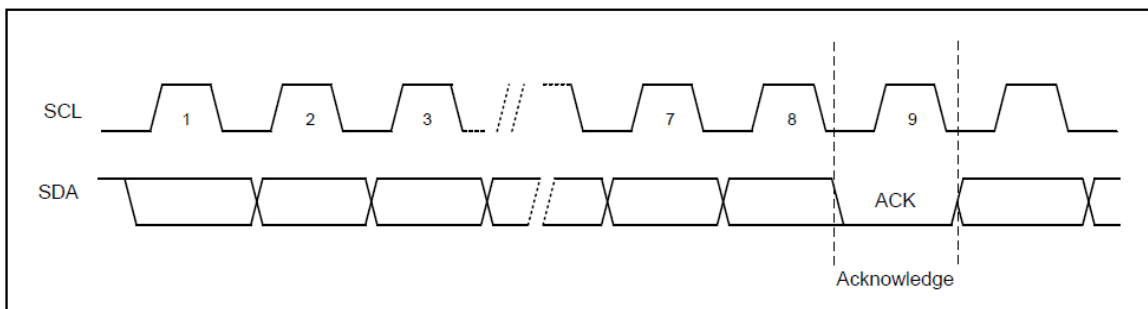

Figure5 : Output Acknowledge

## Standby Mode

The ACE24C256C features a low-power standby mode which is enabled: (a) after a fresh power up, (b) after receiving a STOP bit in read mode, and (c) after completing a self-time internal programming operation



# ACE24C256C Two-wire serial EEPROM

## Soft Reset

After an interruption in protocol, power loss or system reset, any two-wire part can be reset by following these steps: (a) Create a start condition, (b) Clock nine cycles, and (c) create another start bit followed by stop bit condition, as shown below. The device is ready for the next communication after the above steps have been completed.

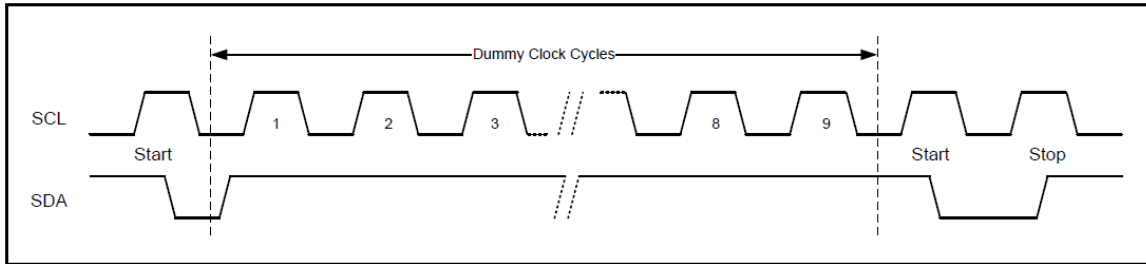

Figure6 : Soft Reset

## Device Addressing

The ACE24C256C requires an 8-bit device address word following a start condition to enable the chip for a read or write operation (see Figure7). The device address word consists of a mandatory one-zero sequence for the first four most-significant bits, as shown.

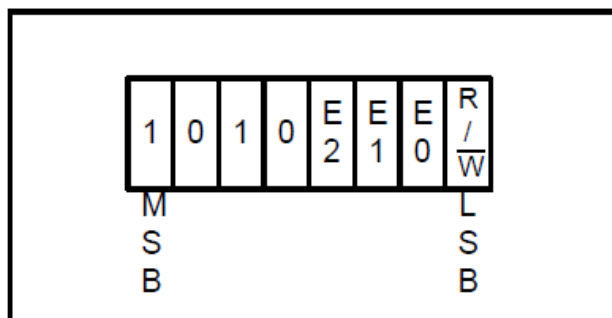

Figure7 : Device Address

The three E2, E1, and E0 device address bits allow as many as eight devices on the same bus. These bits must compare to their corresponding hardwired input pins.

The E2, E1, and E0 pins use an internal proprietary circuit that biases them to a logic low condition if the pins are floating.

The eighth bit of the device address is the read/write operation select bit. A read operation is initiated if this bit is high and a write operation is initiated if this bit is low. Upon a compare of the device address, the Chip will output a zero. If a compare is not made, the device will return to a standby state.

## Data Security

ACE24C256C has a hardware data protection scheme that allows the user to write protect the whole memory when the WCB pin is at  $V_{CC}$ .





# ACE24C256C Two-wire serial EEPROM

## Instructions

### Write Operations

#### (A) Byte Write

A write operation requires two 8-bit data word address (A14/A0) following the device address word and acknowledgment. Upon receipt of this address, the ACE24C256C will again respond with a “0” and then clock in the first 8-bit data word. Following receipt of the 8-bit data word, the ACE24C256C will output a “0” and the addressing device, such as a microcontroller, must terminate the write sequence with a stop condition. And then the ACE24C256C enters an internally timed write cycle, all inputs are disabled during this write cycle and the ACE24C256C will not respond until the write is complete (see Figure 8).

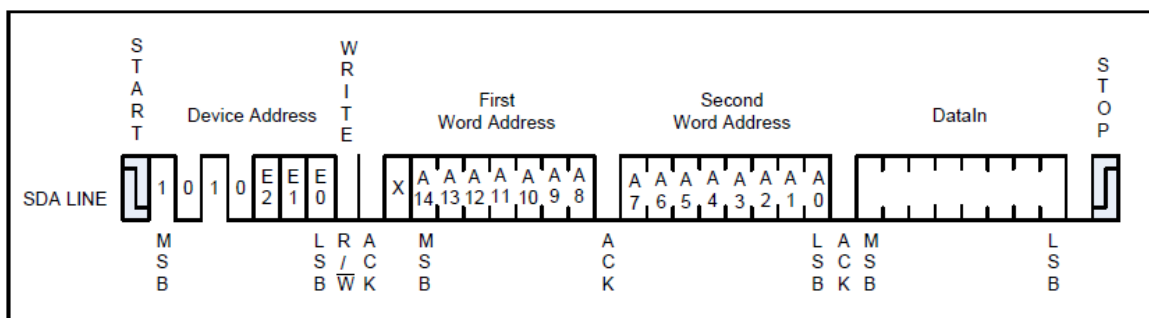

Notes: x means don't care.

Figure8 : Byte Write

#### (B) Page Write

A page write is initiated the same as a byte write, but the master does not send a stop condition after the first data word is clocked in. Instead, after the ACE24C256C acknowledges receipt of the first data word, the master can transmit more data words. The ACE24C256C will respond with a “0” after each data word received. The microcontroller must terminate the page write sequence with a stop condition.

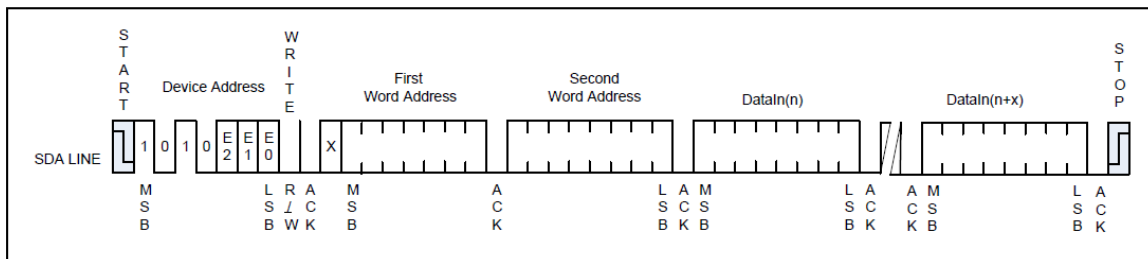

Figure9 : Page Write

The lower six bits of the data word address are internally incremented following the receipt of each data word. The higher data word address bits are not incremented, retaining the memory page row location. When the word address, internally generated, reaches the page boundary, the following byte is placed at the beginning of the same page. If more than 64 data words are transmitted to the ACE24C256C, the data word address will roll-over, and previous data will be overwritten. The address roll-over during write is from the last byte of the current page to the first byte of the same page.



## ACE24C256C Two-wire serial EEPROM

### (C) Acknowledge Polling

Once the internally timed write cycle has started and the ACE24C256C inputs are disabled, acknowledge polling can be initiated. This involves sending a start condition followed by the device address word. The read/write bit is representative of the operation desired. Only if the internal write cycle has completed will the ACE24C256C respond with a “0”, allowing the read or write sequence to continue.

### (D) Write Identification Page

The Identification Page (64 bytes) is an additional page which can be written and (later) permanently locked in Read-only mode. It is written by the Write Identification Page instruction. This instruction uses the same protocol and format as Page Write (into memory array), except for the following differences:

- Device type identifier = 1011b
  - MSB address bits A14/A6 are don't care except for address bit A10 which must be „0“.
- LSB address bits A5/A0 define the byte address inside the Identification page. If the Identification page is locked, the data bytes transferred during the Write Identification Page instruction are not acknowledged (NoACK).

### (E) Lock Identification Page

The Lock Identification Page instruction (Lock ID) permanently locks the Identification page in Read-only mode. The Lock ID instruction is similar to Byte Write (into memory array) with the following specific conditions:

- Device type identifier = 1011b
- Address bit A10 must be „1“; all other address bits are don't care
- The data byte must be equal to the binary value xxxx xx1x, where x is don't care

## Read Operations

Read operations are initiated the same way as write operations with the exception that the read/write select bit in the device address word is set to “1”. There are three read operations: Current Address Read; Random Address Read and Sequential Read.

### (A) Current Address Read

The internal data word address counter maintains the last address accessed during the last read or write operation, incremented by one. This address stays valid between operations as long as the chip power is maintained. The address roll-over during read is from the last byte of the last memory page to the first byte of the first page.

Once the device address with the read/write select bit set to “1” is clocked in and acknowledged by the ACE24C256C, the current address data word is serially clocked out. The microcontroller does not respond with an input “0” but does generate a following stop condition (see Figure 10).



# ACE24C256C Two-wire serial EEPROM

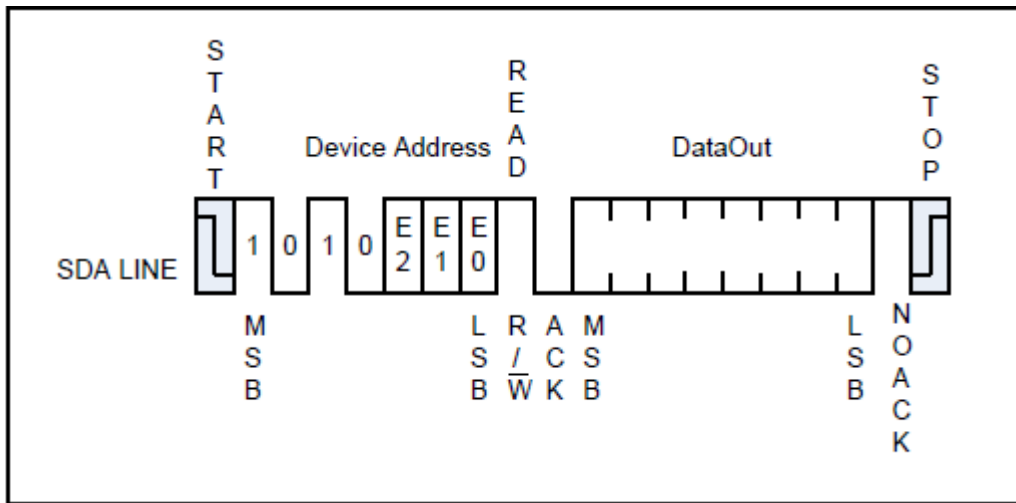

Figure10 : Current Address Read

## (B) Random Read

A Random Read requires a “dummy” byte write sequence to load in the data word address. Once the device address word and data word address are clocked in and acknowledged by the ACE24C256C, the microcontroller must generate another start condition. The microcontroller now initiates a Current Address Read by sending a device address with the read/write select bit high. The ACE24C256C acknowledges the device address and serially clocks out the data word. The microcontroller does not respond with a “0” but does generate a following stop condition (see Figure 11).

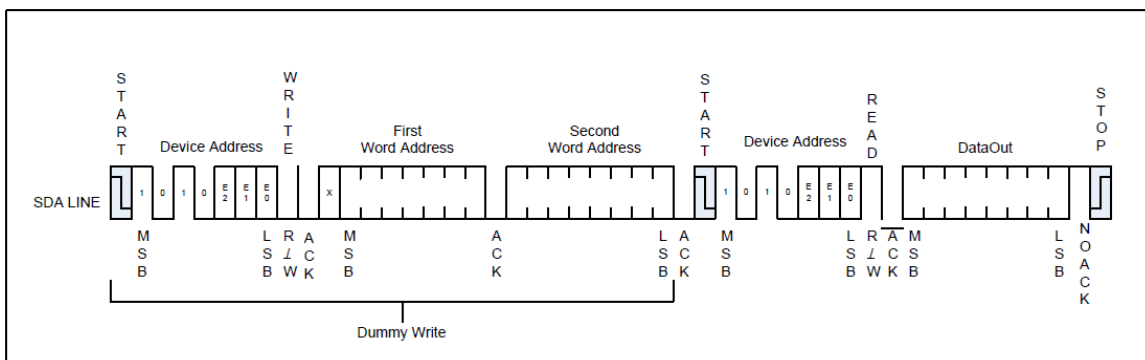

Figure11 : Random Read

## (C) Sequential Read

Sequential Reads are initiated by either a Current Address Read or a Random Address Read. After the microcontroller receives a data word, it responds with acknowledge. As long as the ACE24C256C receives acknowledge, it will continue to increment the data word address and serially clock out sequential data words. When the memory address limit is reached, the data word address will roll-over and the Sequential Read will continue. The Sequential Read operation is terminated when the microcontroller does not respond with a “0” but does generate a following stop condition (see Figure 12)



# ACE24C256C Two-wire serial EEPROM

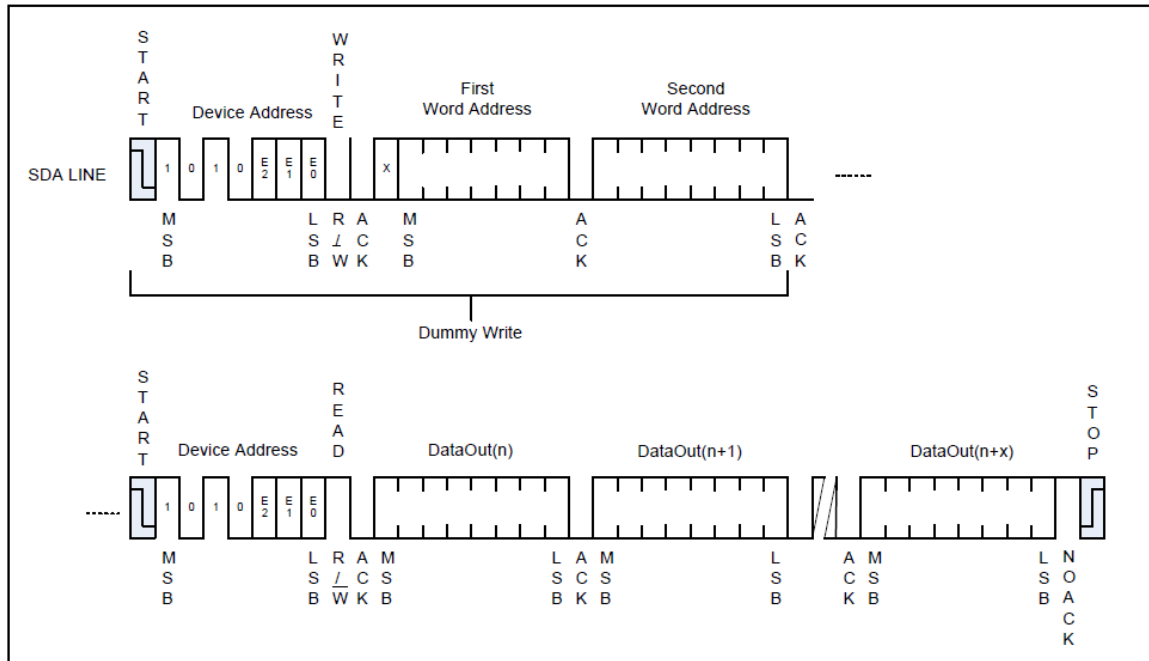

Figure12 : Sequential Read

(D) Read Identification Page

The Identification Page (64 bytes) is an additional page which can be written and (later) permanently locked in Read-only mode. The Identification Page can be read by Read Identification Page instruction which uses the same protocol and format as the Read Command (from memory array) with device type identifier defined as 1011b. The MSB address bits A14/A6 are don't care, the LSB address bits A5/A0 define the byte address inside the Identification Page. The number of bytes to read in the ID page must not exceed the page boundary (e.g. when reading the Identification Page from location 10d, the number of bytes should be less than or equal to 54, as the ID page boundary is 64 bytes).

(E) Read Lock Status

The locked/unlocked status of the Identification page can be checked by transmitting a specific truncated command [Identification Page Write instruction + one data byte] to the device. The device returns an acknowledge bit if the Identification page is unlocked, otherwise a NoACK bit if the Identification page is locked.

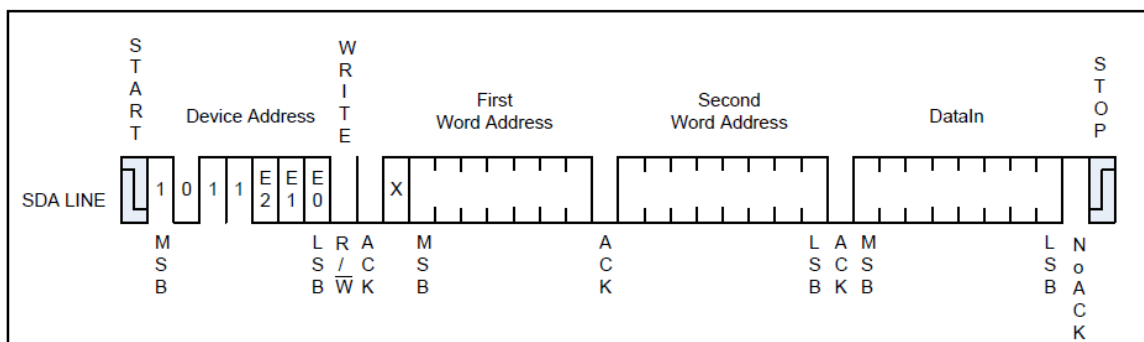

Figure13 : Lock Status Read (When Identification page locked, return NoACK after one data byte)



# ACE24C256C Two-wire serial EEPROM

## Packaging information

### DIP-8

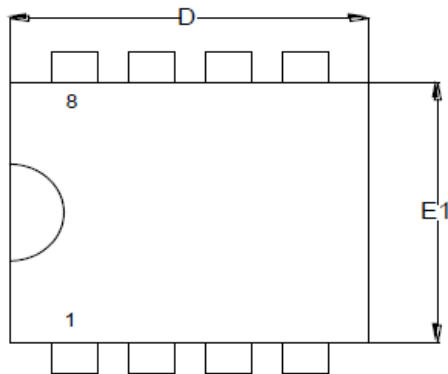
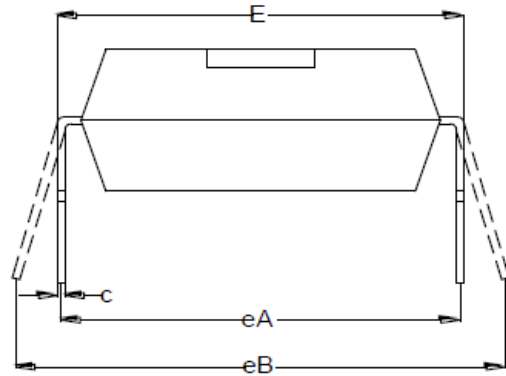
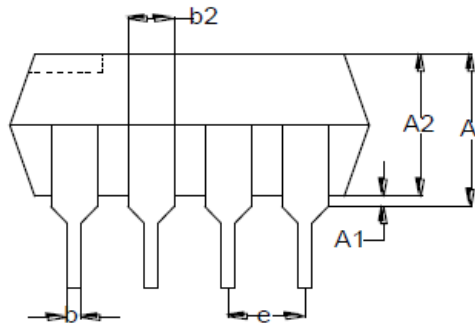

Common Dimensions  
(Unit of Measure=millimeters)

Symbol	Min	Typ	Max
A			5.330
A1	0.380		
A2	2.920	3.300	4.950
b	0.360	0.460	0.560
b2	1.140	1.520	1.780
c	0.200	0.250	0.360
D	9.020	9.270	10.16
E	7.620	7.870	8.260
E1	6.100	6.350	7.110
e		2.540	
eA		7.620	
eB			10.92
L	2.920	3.300	3.810

Note1. Dimensions are not to scale



# ACE24C256C Two-wire serial EEPROM

## Packaging information

### SOP-8

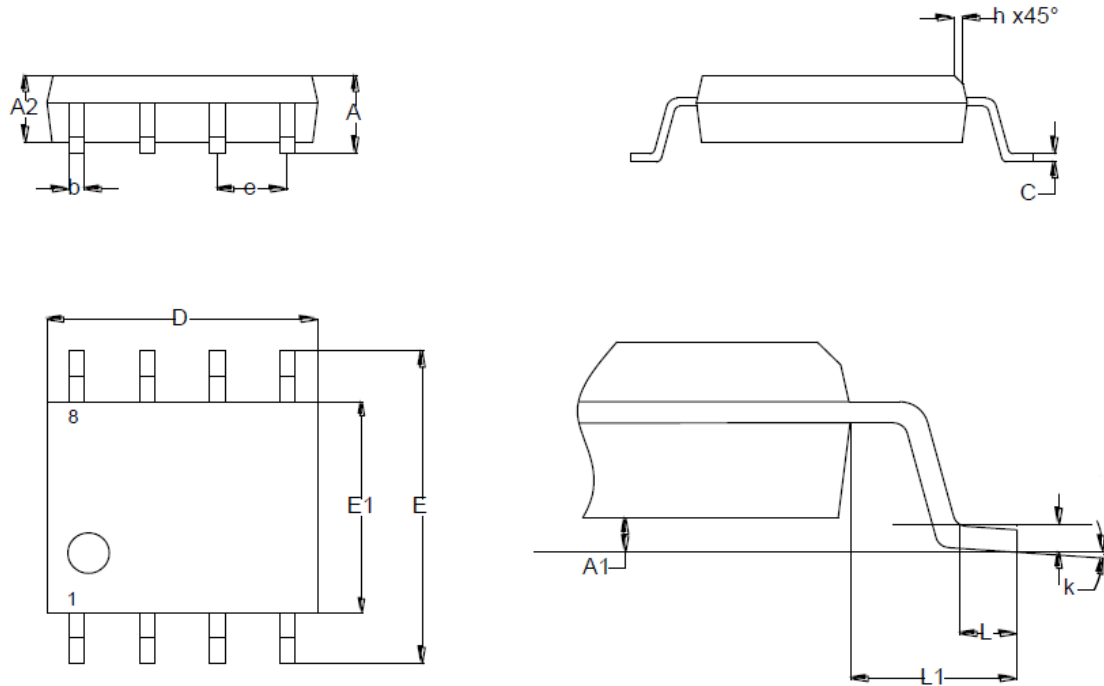

Common Dimensions  
(Unit of Measure=millimeters)

Symbol	Min	Typ	Max
A			1.750
A1	0.100		0.250
A2	1.250		
b	0.280		0.480
c	0.170		0.230
D	4.800	4.900	5.000
E	5.800	6.000	6.200
E1	3.800	3.900	4.000
e		1.270	
h	0.250		0.500
k	0°		8°
L	0.400		1.270
L1		1.040	

Note1. Dimensions are not to scale



# ACE24C256C Two-wire serial EEPROM

## Packaging information

### TSSOP-8

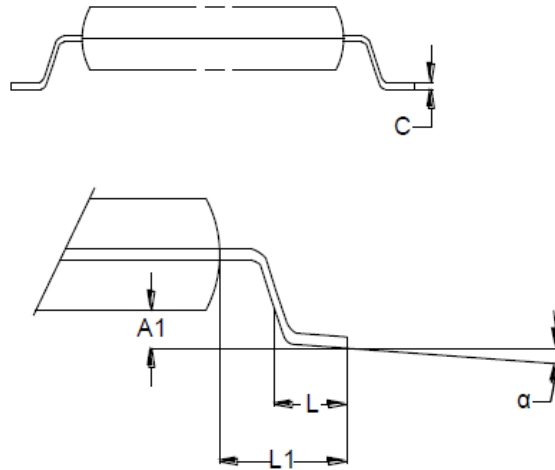
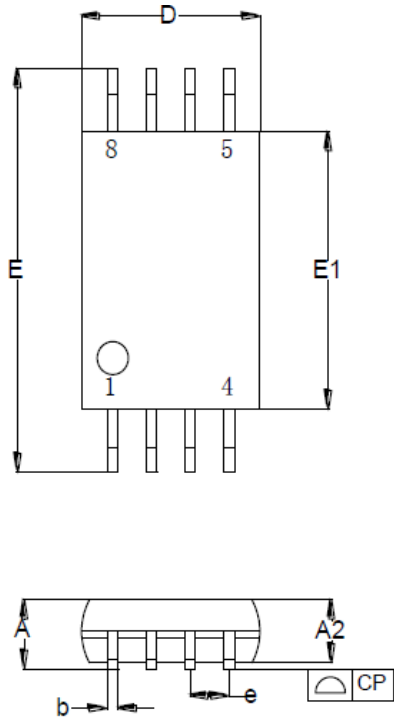

Common Dimensions  
(Unit of Measure=millimeters)

Symbol	Min	Typ	Max
A			1.200
A1	0.050		0.150
A2	0.800	1.000	1.050
b	0.190		0.300
c	0.090		0.200
CP			0.100
D	2.900	3.000	3.100
e		0.650	
E	6.200	6.400	6.600
E1	4.300	4.400	4.500
L	0.450	0.600	0.750
L1		1.000	
$\alpha$	0°		8°

Note1. Dimensions are not to scale



# ACE24C256C Two-wire serial EEPROM

## Packaging information

### MSOP-8

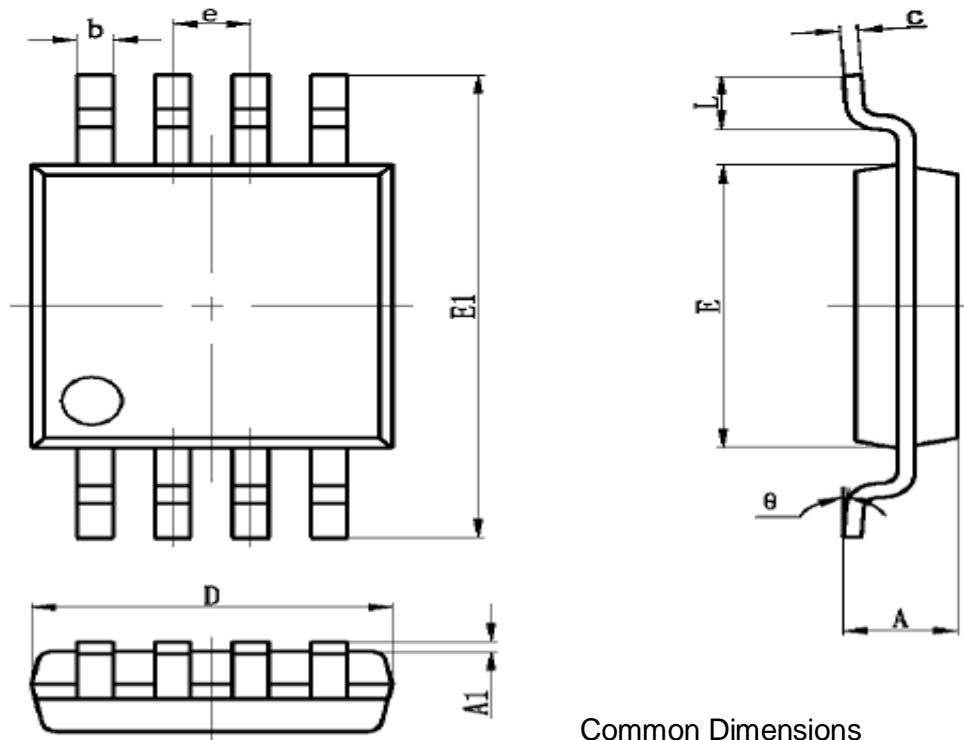

Common Dimensions  
(Unit of Measure=millimeters)

Symbol	Min	Typ	Max
A	0.820		1.100
A1	0.020		0.150
b	0.220		0.380
c	0.080		0.230
D	2.900		3.100
e	0.650(BSC)		
E	2.900		3.100
E1	4.750		5.050
L	0.400		0.800
$\theta$	0°		8°

Note1. Dimensions are not to scale





# ACE24C256C Two-wire serial EEPROM

## Packaging information

### TDFN-8

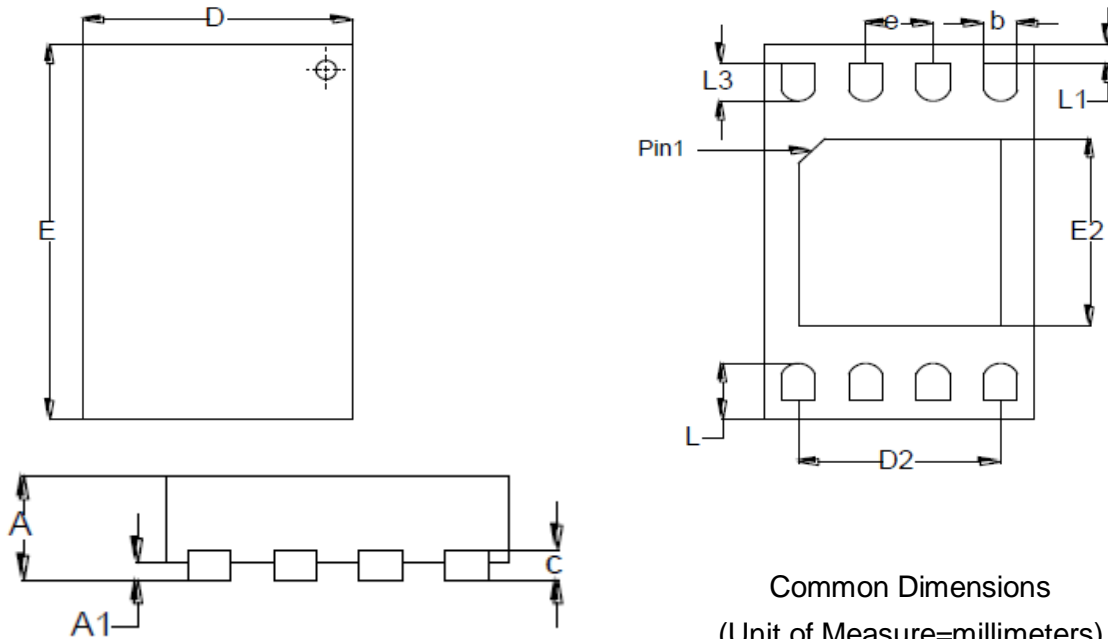

Common Dimensions  
(Unit of Measure=millimeters)

Symbol	Min	Typ	Max
A	0.700	0.750	0.800
A1	0.000	0.020	0.050
b	0.180	0.250	0.300
D	1.900	2.000	2.100
D2(rev MC)	1.400	1.500	1.600
E	2.900	3.000	3.100
E2(rev MC)	1.500	1.600	1.700
e		0.500	
L	0.300	0.400	0.500
L1			0.150
L3	0.300		
c	0.180	0.200	0.250

Note1. Dimensions are not to scale



# ACE24C256C Two-wire serial EEPROM

## Packaging information

### USON3\*2-8

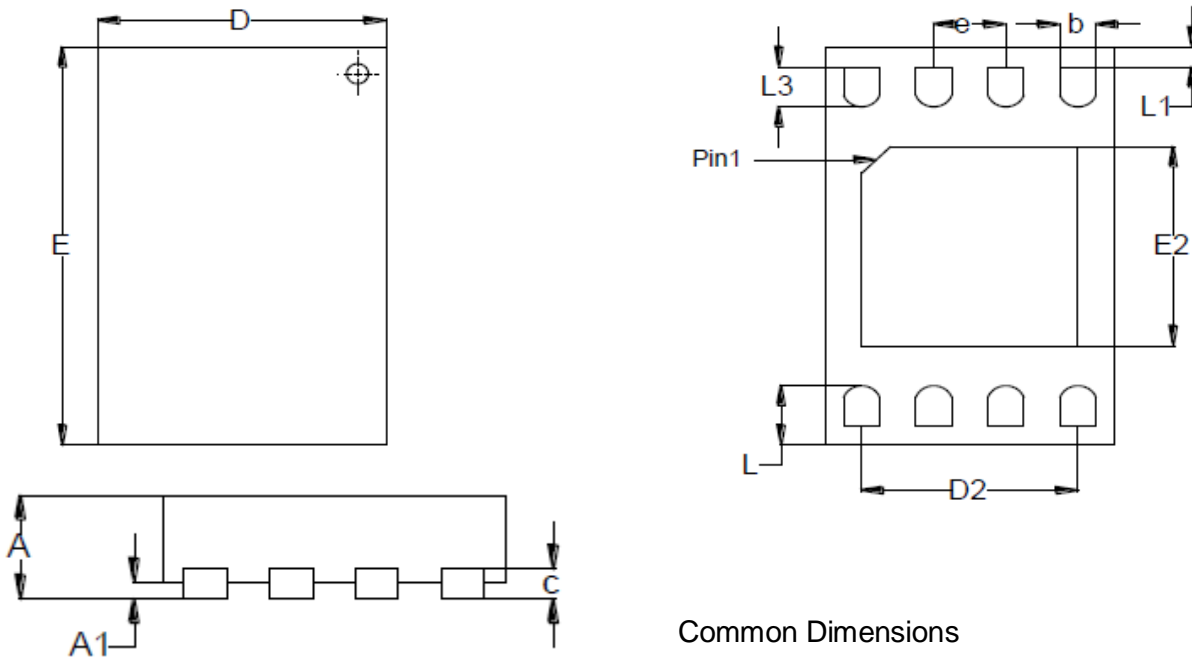

Common Dimensions  
(Unit of Measure=millimeters)

Symbol	Min	Typ	Max
A	0.450	0.500	0.550
A1	0.000	0.020	0.050
b	0.180	0.250	0.300
D	1.900	2.000	2.100
D2(rev MC)	1.400	1.500	1.600
E	2.900	3.000	3.100
E2(rev MC)	1.500	1.600	1.700
e		0.500	
L	0.300	0.400	0.500
L1			0.150
L3	0.300		
c	0.100	0.150	0.200

Note1. Dimensions are not to scale



# ACE24C256C Two-wire serial EEPROM

## Packaging information

### SOT23-5

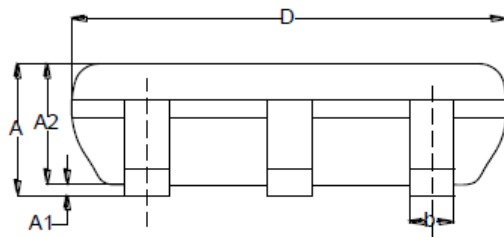
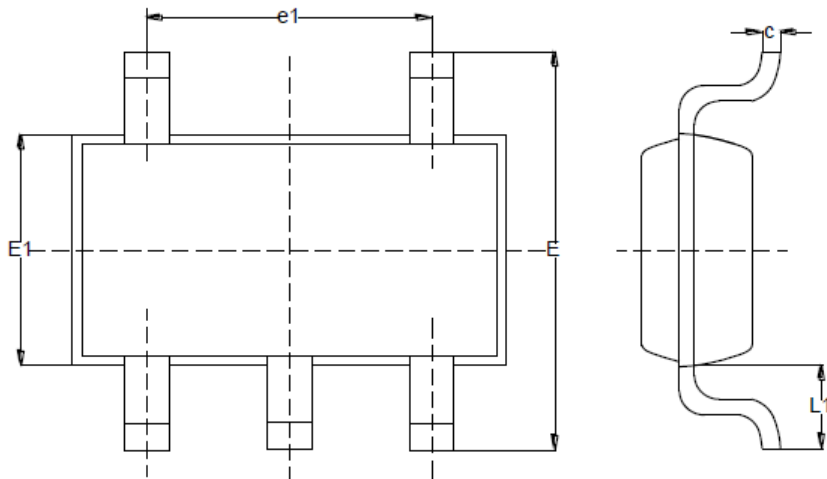

Common Dimensions  
(Unit of Measure=millimeters)

Symbol	Min	Typ	Max
A	1.000		1.250
A1	0.030		0.090
A2	1.050		1.150
c	0.080		0.200
D	0.290BSC		
E	2.800BSC		
E1	1.600BSC		
e	0.950BSC		
e1	1.900BSC		
L1	0.600REF		
b	0.300		0.450

Note1. Dimensions are not to scale



# ACE24C256C

## Two-wire serial EEPROM

### Notes

ACE does not assume any responsibility for use as critical components in life support devices or systems without the express written approval of the president and general counsel of ACE Electronics Co., LTD. As used herein:

1. Life support devices or systems are devices or systems which, (a) are intended for surgical implant into the body, or (b) support or sustain life, and whose failure to perform when properly used in accordance with instructions for use provided in the labeling, can be reasonably expected to result in a significant injury to the user.
2. A critical component is any component of a life support device or system whose failure to perform can be reasonably expected to cause the failure of the life support device or system, or to affect its safety or effectiveness.

ACE Technology Co., LTD.  
<http://www.ace-ele.com/>